

Product Catalogue
10/2023

Wooden windows

activPilot Topstar

Fully-concealed turn-tilt fittings for design windows.

NEW



1

The processing details regarding burglary-resistant window units can be gathered from the DIN EN 1627 - 1630 system documentation. The lists of fittings in this catalogue are merely intended to give application examples. Get in touch with your Winkhaus contact partner for more details.



Complementary range activPilot Topstar

This catalogue is to provide detailed information on the activPilot Topstar product range. The activPilot Topstar turn-tilt fitting range is a complement to our extensive activPilot portfolio. You can find the standard activPilot components in our activPilot Concept product catalogue. If you don't have it on hand, request our catalogue. We remain at your disposal for further questions.

New hinge side for activPilot Topstar

What has changed ?

- Increase of the lateral adjustment in the lower hinge area to ± 2.5 mm.
- Increased service life according to DIN 13126-8 H3 to 20,000 switching cycles (when sash hinge rail is used *).
- Increase of the max. permissible sash weight to 150 kg
- (when sash hinge rail is used *).

* Observe areas of application!

Which components are new?

- Corner hinge EL...IF-N
- Sash hinge FL...IF-N
- Shear S...IF-N
- Turn hinge DL...IF-N



Please note! Fitting parts of the old hinge side must not be mixed with the new-generation fitting parts!

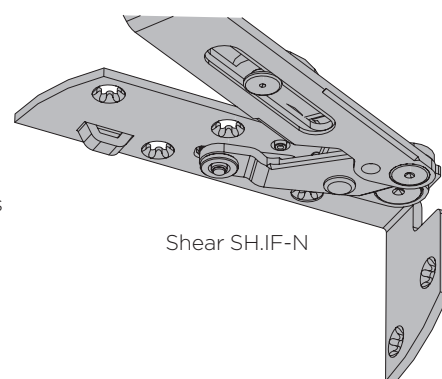

Shear SH...IF-N

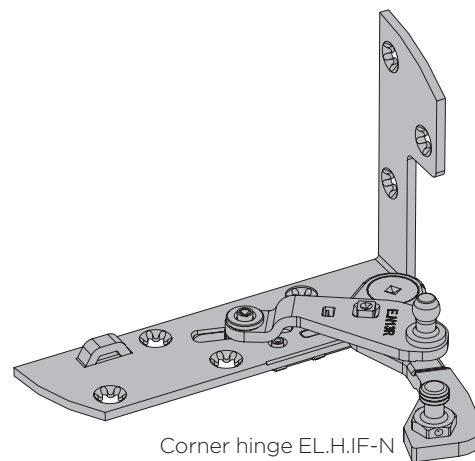

Corner hinge EL...IF-N

The following information and illustrations reflect the current state of our development and manufacturing of this product. In order to achieve customer satisfaction and reliability of the hardware components we reserve the right to change the product. Any information given in this document has been compiled and verified with the greatest care. Some of the indicated dimensions are rounded measures! Due to the constant technical progress, changes in legislation and other inevitable changes, we cannot accept any responsibility for the accuracy and completeness of the contents. We are always thankful for suggestions and comments. Taking into account the information and facts given here with regard to windows (and doors), the fitting system can easily be installed.

Copyright:

© Aug. Winkhaus GmbH & Co. KG, all rights and modifications are reserved.

		Page	
1	General product information	2-21	1
2	Lists of Fittings	22-57	2
3	Drive rods		3
4	Corner drives	58	4
5	Top rods	59-60	5
6	Sash hinges/Corner hinges	61-62	6
7	Shears/Shear hinges	63	7
8	Turn hinges/Tilt hinges	64-65	8
9	Extension rods		9
10	Accessories	66-70	10
11	Frame parts	71-79	11
12	Mounting accessories	80	12
13	Installation Instructions	81-108	13
14	Adjustment/maintenance	109-113	14
15	Installation drawings	114-116	15

1

activPilot Topstar

For wooden windows with high aesthetic demands.

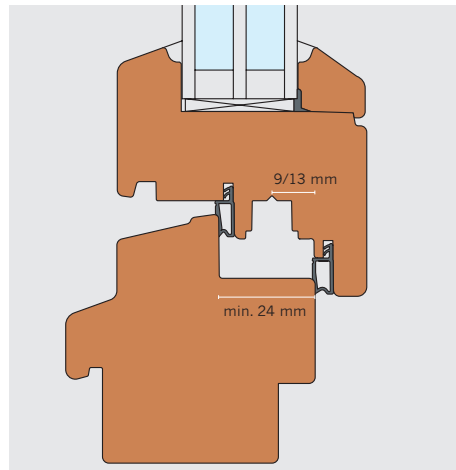
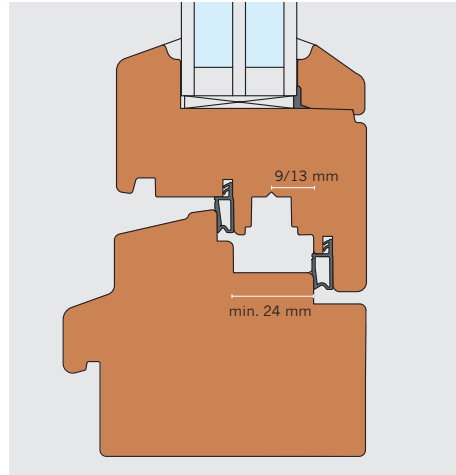

Technical features

- Is used for 9 mm and 13 mm groove centre position from a rebate depth of 24 mm
- Suitable for sash weights of up to 130 kg without requiring additional parts for load transfer
- For flush and offset wooden profiles
- Suitable for narrow frames with small free sizes of the frame

Advantages of the fitting system

- + Easy to combine with the modular activPilot system
- + Compatible with top rails from the activPilot Select product segment
- + Simple three-dimensional adjustment
- + Convenient installation – simply lower the sash on the hinge brackets in a slightly tilted position
- + Energy efficiency – sealing plane is not interrupted
- + Opening angle 95°

activPilot Topstar

1

As a leading manufacturer of fully-concealed fitting solutions Winkhaus is always keen to develop its products consistently and to adapt them to the changing requirements of the customers. The result of this process is activPilot Topstar. activPilot Topstar unites the advantages of energy efficiency and load capacity of large and heavy windows which are required to offer superior design without visible hinges. activPilot Topstar seamlessly integrates with the existing fully-concealed fitting solutions activPilot Elegance and activPilot Select adding further solution possibilities in the field of design windows. Thanks to the activPilot Topstar's movement kinematics directed inwardly, it is possible to manufacture flush windows with narrow shadow joints from 4 mm. In offset profiles it is possible to achieve a free size of the frame from 4 mm to the wall reveal. For the production of activPilot Topstar fittings we use high-tensile steel in order to enable the sashes weighing up to 130 kg to be securely operated in spite of the compact design. In addition, highly-hardened stainless steel keeps help to reduce wear and tear on sensitive friction surfaces improving the endurance of hinge components. When developing the activPilot Topstar fitting system we attached much importance not only to the technical features, but also to the assembly friendliness and the easy accessibility of the adjustment screws. When the sash is lowered in the tilt position onto the corner hinge, the bearing points are located as if by themselves. This prevents the hinges from being subjected to adverse loads from the outset.

Modular design

activPilot optimises window construction. For the window builder, less components and multifunctionality mean uncomplicated and fast processing and rational mounting. Pre-mounted components and the unique design additionally ensure that additional functions and safety classes can be achieved easily by retrofitting. activPilot thus sets the scene for sustainably cutting your production, warehousing, logistics and administration costs.

The locking system with octagonal locking bolts

activPilot enhances comfort. The functionally perfect locking mechanism not only guarantees precise entry of the locking bolt into the frame keep, but also a perfect seal. This is ensured by the increased air gap tolerance and the new octagonal locking bolt which allows easy adjustment of the contact pressure. Even adjusting forces and the non-positive and positive system fit of the components give this fitting the required stability and long-term functionality.

Add-on functions

activPilot gives you the ability to react flexibly to customer requests. Innovative multi-purpose components make it easy to retrofit features at any time. The use of a duo and/or tri functional element makes it simple to add a fail safe device with integrated limiter support and balcony door catch. The variable tilt device supports different sash tilt angles and thus fast, easily adjustable ventilation settings.

Design

activPilot offers you and your customers real added value. Surprising details, discreet accents, ergonomic design and comprehensive functions characterise the overall concept of the fitting system. In short its attractive design will be a crucial factor when it comes to your customers making a purchase decision. activPilot also offers other convincing arguments such as outstanding durability, easy-to-clean surfaces, intuitive operation and, last but not least, aesthetically pleasing windows.

Surface

activPilot fittings feature a surface refinement finish based on nanotechnology, which is applied in our in-house plating shop. This surface stands out due to its very high resistance to all environmental influences. This is verified by quality controls consisting of alternate climate and salt spray testing according to DIN EN ISO 9227 and is certified by tests on a regular basis. Winkhaus also carries out tests in outside areas, thus testing component behaviour under realistic conditions. This enables Winkhaus to offer a ten-year warranty for functions and surfaces.

Effective security

Thanks to this unique modular system, any window can be modified to achieve the required security standard - easily, quickly and cost-efficiently. There is no need for custom parts. Depending on the number and type of keeps, various security levels are achievable using the same platform. At our works, comprehensive and strict tests - along with ongoing functional monitoring - ensure maximum security for customers. Approval marks and certificates by independent test authorities confirm our results. You can therefore rely on activPilot meeting customer requirements for a secure fitting system. Locking bolts are made of high-strength steel; even standard types guarantee effective basic security. Depending on the number and type of keeps, the fitting system can be enhanced for compliance with stricter security classes - including burglar protection to DIN V ENV 1627-1630, RC2.

1

Quality standard

The Winkhaus group successfully passed a group certification of production sites according to DIN EN ISO 9001:2015 / DIN EN ISO 50001:2011. The group certification ensures that we use the same criteria and procedures in all Winkhaus subsidiaries and thus we can always offer consistent quality for our customers.



We successfully passed the demanding QM 328 certification.

activPilot fittings from Winkhaus are certified in accordance with QM 328. The turn-only and turn-tilt fittings for windows and patio doors undergo a large number of tests in this stringent certification programme, which verifies aspects such as durability and quality control mechanisms. The certificate stands as a testament to Winkhaus' long tradition in high quality products.

Endurance test

Winkhaus activPilot is certified in accordance with EN 13126-8 (endurance test for turn-only and turn-tilt fittings) and EN 1191 (endurance test for windows and doors). The fitting thus complies with EN standards. Winkhaus' own permanent control in accordance with established production control guidelines as well as regular external monitoring by ift Rosenheim ensure outstanding product quality guaranteed on a long-term basis.

Your partner for service

Our services are solution-orientated, reliable and precisely geared to match your requirements - just as you would expect from your partner. We are at your disposal whenever you need us. With application engineers on site, professional help from our product data service and innovative software solutions to help optimise your workflows, we ensure you are able to work as you require and also broaden your professional service capabilities. What's more, our comprehensive product information system and sophisticated logistics guarantee fast delivery any time you need it.

Proper screw fixing in terms of load of security-relevant fitting components

In order to ensure the endurance and operating safety of windows and balcony doors over their expected service life, major importance must be attached to the installation of security-relevant fitting components! Manufacturers of windows and balcony doors are responsible for fixing the fitting elements on the sash and the frame in a professional way and they must make sure that the specifications are adhered to. Important: Follow these guidelines! Always use screws that are long enough to bear the loads.

Basic technical features of the activPilot fitting system

In the following section you will find the general features that apply to all activPilot fitting components in the sash area, unless otherwise described on the corresponding product pages.

- Face plate width of sash fitting parts: 16 mm
- Overlapping system linkage without connecting plates
- Delivery state of sash fitting parts: centre fixed in turn position
- Safety locking pin as an adjustable octagonal bolt
- Sash fitting parts can be used right/left, unless otherwise stated.

Zertifikat / Certificate



Zertifikatsnr. / Certificate No.: 228-7019950-1-17

Dreh- und Drehkipppbeschläge für Fenster und Fenstertüren Turn and tilt-turn hardware for windows and casement doors

Produkt
product
activPilot, proPilot

max. Flügelgewicht
max. casement weight
max 200 kg

Einsatzbereich
field of application
Systeme mit entsprechender Beschlagaufnahme
Systems with suitable hardware groove

Hersteller
manufacturer
Aug. Winkhaus GmbH & Co. KG
August-Winkhaus-Str. 31, D 48291 Telgte

Produktionsstandort
production site
Aug. Winkhaus GmbH & Co. KG
August-Winkhaus-Str. 31, D 48291 Telgte



Mit diesem Zertifikat wird bescheinigt, dass das benannte Bauprodukt den Anforderungen des zugrundeliegenden ift-Zertifizierungsprogramms in der aktuellen Fassung entspricht.

- Erstellung von Produktfamilien des aufgeführten Bauproduktes und Erstprüfung durch eine akkreditierte Prüfstelle nach EN 13126-8:2017 unter Berücksichtigung der Anwendungsdiagramme
- Einführung und Aufrechterhaltung einer werkseigenen Produktionskontrolle durch den Hersteller
- Erstinspektion des Werkes und der werkseigenen Produktionskontrolle durch ift-Q-Zert
- kontinuierliche Fremdüberwachung des Werkes und der werkseigenen Produktionskontrolle durch ift-Q-Zert

Dieses Zertifikat wurde erstmals am 18. November 2008 ausgestellt und gilt 5 Jahre, wenn sich zwischenzeitlich die Festlegungen in der oben angeführten technischen Spezifikation oder die Herstellbedingungen im Werk oder in der werkseigenen Produktionskontrolle selbst nicht wesentlich verändert haben.

Das Zertifikat darf nur unverändert vervielfältigt werden. Alle Änderungen der Voraussetzungen für die Zertifizierung sind dem ift-Q-Zert mit den erforderlichen Nachweisen unverzüglich schriftlich anzuzeigen.

Das Unternehmen ist berechtigt, das benannte Bauprodukt gemäß der ift-Zeichensatzung mit dem „ift-zertifiziert“-Zeichen zu kennzeichnen.

Dieses Zertifikat enthält 2 Anlage/n.

This certificate attests that the building product mentioned fulfils the requirements of the underlying ift-certification scheme in its current version.

- compilation of product families of the building product listed and initial type-testing by an accredited testing body as per EN 13126:8:2017 based on the application diagrams
- implementation and maintenance of a factory production control by the manufacturer
- initial inspection of the production site and the factory production control by ift-Q-Zert
- continuous third-party control of the production site and the factory production control by ift-Q-Zert

This certificate was first issued on 18. November 2008 and will remain valid for 5 years, as long as neither the conditions laid down in the technical specification listed above nor the manufacturing conditions in the production site nor the factory production control itself are modified significantly.

The reproduction of the certificate without any change from the original is permitted. Any changes to the prerequisites applicable to certification shall be immediately communicated in writing to ift-Q-Zert accompanied by the necessary evidence.

The company is authorized to affix the "ift-certified"-mark to the building product mentioned according to the ift-rules for use of the "ift-certified"-mark.

This certificate contains 2 annexes.

Grundlage(n) / Basis:

ift-Zertifizierungsprogramm für Beschläge
ift-certification scheme for hardware (QM 328)
Ausgabe/Issue 2018

EN 1191
EN 12400
bis Klasse 3
up to class 3



Dauerfunktion
resistance to repeated opening and closing

EN ISO 9227
EN 1670
bis Klasse 5
up to class 5



Korrosionsschutz
corrosion protection

Christian Kehrer

ift Rosenheim
25. März 2019

Christian Kehrer
Leiter der ift-Zertifizierungs- und Überwachungsstelle
Head of ift Certification and Surveillance



Ulrich Sieberath

Prof. Ulrich Sieberath
Institutsleiter
Director of Institute

228 7019950

Gültig bis /
Valid until:

10. Oktober 2023

2018-01/1797



www.ift-rosenheim.de

ift Rosenheim GmbH
Theodor-Giell-Str. 7-9
D-83026 Rosenheim

Kontakt
Tel.: +49 8031 281-0
Fax: +49 8031 281-290
www.ift-rosenheim.de

Prüfung und Kalibrierung – EN ISO/IEC 17025
Inspektion – EN ISO/IEC 17020
Zertifizierung Produkte – EN ISO/IEC 17065
Zertifizierung Managementsysteme – EN ISO/IEC 17021

Notified Body 0757
POZ-Stelle: BAY 18



You will find further certificates and updates at www.winkhaus.com

Anlage I annex 1 Seite I page 1 von I of 3
 Hersteller I manufacturer: Aug. Winkhaus GmbH & Co. KG
 Ausgabedatum I date of issue: 25. März 2019



Zertifikatsnr. I Certificate No.: 228-7019950-1-17

In der Zertifizierung enthaltene Produktfamilien für Fenster- und Fenstertürsysteme mit geeigneter Beschlagaufnahme.
Product families for window and casement door systems with groove designed for accommodation of hardware, covered by certification.

Ifd. Nr./ no.	Ausführung Bandseite/ type hinge side	Ausführung Flügelbeschlag/ type casement hardware	Beschreibung der Ausführung der blendrahmenseligen Beschlagausführung detail description of frame member hardware type				Klassifizierung nach EN 13126-8:2017 classification as per EN 13126-8:2017			
			Winkelband/ top stay connecting part	Scherenlager/ stay arm support	Eckband/ corner hinge	Ecklager/ corner pivot	1 Dauerfunktionsfähigkeit/ durability	2 Masse (in kg)/ mass	3 Korrosionsbeständigkeit/ corrosion resistance	4 Prüfgrößen (in mm)/ test sizes
1	activPilot K 100	activPilot K 100	SK2.20-13	SL.KS.3-6	FL.K 20-6-20	EL.K 6-3-16	H2	100	5	1300 mm x 1200 mm
2	activPilot K 100	activPilot K 100	SK2.20-13	SL.KS.3-6	FL.K 20-6-20	EL.K 6-3-16	H2	100	5	900 mm x 2300 mm
3	activPilot K 130 S	activPilot K 130 S	SK2.20-13	SL.K.3-6.130	FL.K 20-6-28.130	ESV 6-3-16	H3	100	5	1300 mm x 1200 mm
4	activPilot Comfort PADK 100	activPilot Comfort PADK 100	SK2.PA.20-13	SL.KS.3-6	FLE.FWPA 20-13	ESV 6-3-16	H2	100	5	1300 mm x 1200 mm
5	activPilot Comfort PADK 100	activPilot Comfort PADK 100	SK2.PA.20-13	SL.KS.3-6	FLE.FWPA 20-13	ESV 6-3-16	H2	100	5	900 mm x 2300 mm
6	activPilot Comfort PADM 100	activPilot Comfort PADM 100	SK2.PAD. 20-13	SL.KS.3-6	FLE.FPAD 20-13	ESV 6-3-16	H2	100	5	1300 mm x 1200 mm
7	activPilot Comfort PADM 100	activPilot Comfort PADM 100	SK2.PAD. 20-13	SL.KS.3-6	FLE.FPAD 20-13	ESV 6-3-16	H2	100	5	900 mm x 2300 mm
8	activPilot C 130	activPilot C 130	SC2.20-13	SL.C.3-6	FL.C-W. 20-13	EL.CS. 6-3-22	H3	130	5	1400 mm x 1550 mm
9	activPilot K 130	activPilot K 130	SK2.20-13	SL.KB.3-6	FWV 20-13	ESVW 6-3-16	H2	130	5	1300 mm x 1200 mm

Anlage I annex 1 Seite I page 2 von I of 3
 Hersteller I manufacturer: Aug. Winkhaus GmbH & Co. KG
 Ausgabedatum I date of issue: 25. März 2019



Zertifikatsnr. I Certificate No.: 228-7019950-1-17

10	activPilot K 130	activPilot K 130	SK2.20-13	SL.KB.3-6	FWV 20-13	ESVW 6-3-16	H2	130	5	900 mm x 2300 mm
11	activPilot ALU 130	activPilot ALU 130	SK2.20-13	SL.KB.3-6	FWV 20-13	ESVW 6-3-16	H2	130	5	1300 mm x 1200 mm
12	activPilot ALU 130	activPilot ALU 130	SK2.20-13	SL.KB.3-6	FWV 20-13	ESVW 6-3-16	H2	130	5	900 mm x 2300 mm
13	activPilot K 130 S	activPilot K 130 S	SK2.20-13	SL.K.3-6.130	FL.K 20-6-28.130	ESV 6-3-16	H2	130	5	1300 mm x 1200 mm
14	activPilot K 130 S	activPilot K 130 S	SK2.20-13	SL.K.3-6.130	FL.K 20-6-28.130	ESV 6-3-16	H2	130	5	900 mm x 2300 mm
15	activPilot H 130	activPilot H 130	SH2.T. 18-13-12	SL.HT.18-12	FL.HT. 18-13-12	EL.HT.Z. 18-12	H3	130	5	1300 mm x 1200 mm
16	activPilot H 150	activPilot H 150	SH2.T. 18-13-12	SL.HT.18-12	FL.HT. 18-13-12	EL.HT.Z. 18-12	H3	150	5	900 mm x 2300 mm
17	activPilot Giant	activPilot Giant	SXL.20-13	SL.XL	FL.XL	EL.XL	H3	200	5	1550 mm x 1400 mm
18	activPilot Giant	activPilot Giant	SXL.20-13	SL.XL	FL.XL	EL.XL	H2	200	5	900 mm x 2300 mm
19	activPilot Select K 100	activPilot Select K 100	SK.SE	ohne without	FL.SE	EL.K.SE	H2	100	5	1300 mm x 1200 mm
20	activPilot Select H 130	activPilot Select H 130	SH.SE. 20-9.Z.	ohne without	FL.SE	EL.H.SE. 20-9.Z. mit/with FLS.SE	H2	130	5	1300 mm x 1200 mm
21	activPilot Topstar	activPilot Topstar	SH.IF.24-13	ohne without	FL.IF	EL.H.IF. 24-13	H2	130	5	1300 mm x 1200 mm

Anlage / annex 1
 Hersteller / manufacturer:
 Ausgabedatum / date of issue:

Seite / page 3 von / of 3
 Aug. Winkhaus GmbH & Co. KG
 25. März 2019



Zertifikatsnr. / Certificate No.: 228-7019950-1-17

22	activPilot Topstar	activPilot Topstar	SH,IF.24-13	ohne without	FL,IF	EL,H,IF.24-13	H2	130	5	900 mm x 2300 mm
23	activPilot Select K 150	activPilot Select K 150	SK,SE	ohne without	FL,SE	EL,K,SE mit/with FLS,SE	H2	150	5	1550 mm x 1400 mm
24	activPilot Select K 150	activPilot Select K 150	SK,SE	ohne without	FL,SE	EL,K,SE mit/with FLS,SE	H2	150	5	900 mm x 2300 mm
25	activPilot Select ALU 150	activPilot Select ALU 150	SK,SE	ohne without	FL,SE	EL,K,SE mit/with FLS,SE	H2	150	5	1550 mm x 1400 mm
26	activPilot Select H 150	activPilot Select H 150	SH,SE.29-13	ohne without	FL,SE	EL,H,SE.29-13 mit/with FLS,SE	H2	150	5	1550 mm x 1400 mm
27	proPilot	proPilot	SK,U.2.20-13	SL,K,U.3-3	FL,K,U.6	EL,K,U.3-3	H2	70	4	1300 mm x 1200 mm
28	proPilot	proPilot	SK,U.2.20-13	SL,K,U.3-3	FL,K,U.6.100	EL,K,U.3-3	H2	100	4	1300 mm x 1200 mm
29	activPilot C 150	activPilot C 150	SC2.20-13	SLC.3-6	FL,C-W.20-13	EL,CS.6-3-22	H3	150	5	900 mm x 2300 mm
30	activPilot C 150	activPilot C 150	SC2.20-13	SLC.3-6	FL,C.20-6-28	EL,C.6-3-22	H3	150	5	900 mm x 2300 mm
31	activPilot C 130	activPilot C 130	SC2.20-13	SLC.3-6	FL,C.20-6-28	EL,C.6-3-22	H3	130	5	1400 mm 1550 mm

Die Ergebnisse sind auf folgende Ausführungsvarianten übertragbar: Beschlagsausführung links/rechts, alle zulässigen Größen gemäß Anwendungsdiagramm sowie andere Falz- und Profilgeometrien. Die technische Dokumentation des Beschlagherstellers, insbesondere die entsprechenden Anwendungsdiagramme, ist zu beachten.
 The results can be applied to the following design variants: hardware type left/right, all permissible sizes in accordance with the application diagram as well as other rebate and profile geometries. Observe technical documents of hardware manufacturer, in particular the relevant diagrams.

Obligations to provide information and instructions

This document brings together important information and details regarding different fittings and their further processing. The information is particularly intended for window and balcony door manufacturers and fitting and structural component retailers. Accidents and physical damage can be avoided if you observe the information contained in this information. For this reason, you must always ensure that you pass on the relevant documents when you hand fittings over to somebody else. Information and documents should be handed over in printed format, on a CD ROM or online, for example.

Guidelines for the use of locking systems and fittings

Gütegemeinschaft Schlösser und Beschläge e.V., Velbert issues guidelines offering assistance for the use of locking systems and fittings for windows, doors and patio doors. These guidelines are established in cooperation with the trade association of the locks and fittings industry in Velbert as well as the testing institute PIV which is also based in Velbert. If required, they are agreed with the VFF technical committee and ift Rosenheim. As a result the experience and test findings of several decades are considered. The guidelines provide information about the intended use and maintenance of fittings for windows and patio doors. It is mandatory to observe these guidelines. The current guidelines can be accessed in different languages at the following Internet address: <http://www.beschlagindustrie.de/ggsb/richtlinien.asp>



As an alternative to using the www address, you can also scan the QR Code with your smartphone!

Follow this link to find the applicable and binding guidelines on the following topics:

- VHBH - Fittings for windows and patio doors [with guidelines / instructions on the product and liability]
- VHBE - Fittings for windows and patio doors [with guidelines / instructions for end users]
- TDBK - Attachment of supporting fitting components of turn and turn-tilt fittings [with definitions of turn and turn-tilt fittings as well as their possible mounting positions]
- FPKF - Safety and cleaning shears for tilt sashes and tilting fanlights [use of safety and cleaning shears]
- FPDF - Sash limiters for variable turn position of sashes [sash limiters controlled by central locking system – definitions and tests]



The VHBH guideline among others contains the chapter “Obligation to give instructions”. A schematic illustration shows the documents and information to be submitted to the different target groups for respecting the instructions obligation. The building owner must pass on the documents defined in the chapter “Obligation to give instructions” to the end user.



Gütegemeinschaft Schlösser und Beschläge e.V.
Richtlinie: TDBK
ORIGINALFABRICATION Ausgabe: 2016-05-05

Richtlinie
Befestigung tragender Beschlagteile von Dreh- und Drehkipp-Beschlägen
mit Definitionen zu Dreh- und Drehkipp-Beschlägen sowie deren möglichen Einbaulagen

Inhalt

1. Vorwort	3
2. Anwendungsbereich	3
3. Begriffe	4
4. Dauerfunktionsfähigkeit – Grenzen der Richtlinie	7
5. Empfehlungen für die Befestigung	8
6. Durchführung der Prüfungen	8
7. Vorgaben zu den Kriterien	15
8. Literaturhinweis	22

Herausgeber:
Gütegemeinschaft Schlösser und Beschläge e.V.
Offerstraße 12
42551 Velbert
Phone: +49 (0)2051 / 95 06 - 0
Fax: +49 (0)2051 / 95 06 - 20
www: www.beschlagindustrie.de
www.beschlagindustrie.de/ggsb/richtlinien.asp

Hinweis
Technische Angaben und Empfehlungen dieser Richtlinie beruhen auf dem Kenntnisstand bei Drucklegung. Es gilt der Inhalt des „Disclaimer“ auf der o.g. Internet-Seite.

Richtlinie | BUK
1 / 23

Product liability guidelines

Turn and turn-tilt fittings for windows and patio doors

According to the current product liability legislation dealing with a manufacturer's liability for his products (§ 4 ProdHaftG) please observe the following information on turn and turn-tilt fittings for window and patio door sashes. The manufacturer will not accept any liability for noncompliance with these specifications.

1. Product information and intended use

Turn and turn-tilt fittings within the meaning of this definition are single handle turn-tilt fittings for windows and patio doors as used in building applications. They are used to bring window and window sashes into a turn position or into a tilt position limited by the shear version using a hand lever. Turn and turn-tilt fittings are used on vertically installed windows and patio doors made of wood, PVC-U, aluminium or steel and their corresponding material combinations. Conventional turn and turn-tilt fittings in the sense of this definition close/lock window and patio door sashes and bring them into different ventilation positions. As a rule, the counterforce of a seal must be overcome when closing. Uses deviating from this do not correspond to the intended use. Burglary-resistant windows and patio doors, windows and patio doors for damp rooms and those for use in environments with aggressive, corrosion-promoting air contents require fittings with performance characteristics coordinated and separately agreed for the respective application. Opened window and patio door sashes only achieve a shielding function and do not meet any requirements for joint tightness, watertightness, sound insulation, thermal insulation and burglary resistance. In wind and draughts, window and window sashes must be closed and locked. Wind and draught in the sense of this definition are present if the window or patio door sashes in one of the opening positions open or close automatically and uncontrollably due to air pressure or air suction. A fixed open position of window and patio door sashes can only be achieved with arresting additional fittings. The resistance to wind loads in closed and locked state depends on the respective constructions of windows and patio doors. If wind loads must be transferred in accordance with DIN EN 12210 (particularly test pressure p_3), suitable fitting combinations must be agreed in conjunction with the respective window construction and the frame material and agreed separately. In general, the turn and turn-tilt fittings can meet the requirements for barrier-free apartments in accordance with DIN 18025. However, this requires corresponding fitting combinations and assemblies in the windows and patio doors, which must be coordinated and agreed separately.

2. Misuse

Misuse – i.e. the use of a product in a manner contrary to the manufacturer's instructions – of turn-tilt fittings for windows and patio doors occurs

- if obstacles are placed in the opening area preventing the intended use.
- if sashes of windows / patio doors are pushed or hit against the window reveal, either contrary to the manufacturer's instructions or in an uncontrolled way (e.g. by wind), that the fittings, the frame materials or other individual parts of the window sash or the patio door sash are damaged or destructed or subsequent damage occurs
- if additional loads act on the sashes of windows or patio doors (e. g. children swinging on them).
- if someone grasps in the gap between the frame and sash when closing the window (risk of injury).

3. Liability

The respective overall fitting must be selected from the original Winkhaus activPilot fitting components range. Winkhaus accepts no liability if non-original or unauthorised system accessory parts are used. Important: The screw / clamping connection of load-bearing fitting components, such as corner, shear and sash hinges must be designed according to the TBDK guidelines. Please adapt the fixing procedure of the fitting components to the load situation.

4. Product performance – Manufacturer's instructions for use

The maximum sash weights for the individual fitting versions may not be exceeded. The component with the lowest permissible loading capacity determines the maximum weight of the sash. Please observe the diagrams and component installation instructions.

4.1 Sash sizes and areas of application

The graphs in the application diagrams show the permitted sash rebate height to width ratios, as determined by different weights of glass and/or overall glass thickness. The resulting sash rebate dimensions or sash formats (portrait/ landscape) as well as the maximum sash weight may under no circumstances be exceeded.

4.2 Application diagram for determination of the permissible sash sizes

The application diagrams for this fitting series for the determination of permissible sash sizes are described and explained separately on the following pages.

4.3 Composition of fittings

You must comply with the manufacturer's specifications regarding the configuration of fittings (e.g. the use of additional shears, the layout of fittings for burglary-resistant windows and patio door sashes, etc.).

5. Product maintenance

Security-relevant fitting parts are to be inspected at least once a year to check for wear and to ensure they are firmly secured in position. Fastening screws must be tightened and faulty components must be replaced as required. In addition, maintenance work must be carried out at least once a year. All mobile parts and locking points for fittings should be greased and tested for function. Only oils and greases not affecting the materials of the fitting may be used. The only cleaning and maintenance materials to be used are those which will not adversely affect the corrosion-resistant properties of the fitting components.



Adjustment work to the fittings - particularly in the area of the corner drive and the shears - as well as the replacement of parts and mounting and removal of opening sashes must be carried out by a trained specialist.

5.1 Maintaining surface quality

- The fittings and rebate spaces must be adequately ventilated, particularly during the construction stage, so that they are not exposed to the direct effects of moisture or condensation. It must be ensured in any case by appropriate measures that there is no possibility for (permanently) humid room air to condense in the rebate area.
- The fittings must be kept free from deposits and soiling due to building materials (building dust, gypsum plaster, cement etc). Possible soiling from plaster, mortar etc. must be removed prior to bonding with water.
- Corrosive vapours (e.g. formic acid, acetic acid, ammonia, amine and ammonia compounds, aldehydes, phenols, chlorine, tannic acid etc.) combined with even a small amount of condensation can cause rapid corrosion of the fittings. Therefore, such evaporation in the area of the windows must be avoided at all costs.

- Furthermore no sealants that cure with acetic or other acids, or sealants containing any of the above-mentioned substances, must be used. Both direct contact with the sealant and vapours released from it can damage the surface.
- Only use a mild and pH neutral detergent in diluted form to clean the fittings. Under no circumstances use aggressive acidic cleaners or scouring agents containing the substances listed above.

6. Obligations to provide information and instructions

For the implementation of information and instruction obligations as well as for the maintenance work the following documents are available. They must be submitted to (intermediate) dealers and manufacturers and to the end customer.

Planning documentation

Product catalogues

Installation Instructions

Maintenance and care instructions as well as operating instructions

















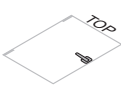
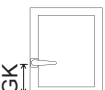

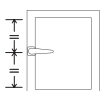

7. Use of type-related fittings

The variants for the individual fitting systems (e.g. tilt and top-hung sash fittings or parallel action fittings providing an additional ventilation position by means of a circumferential gap all around the sash) are to be handled accordingly with regard to product information and intended use, misuse, product performance, product maintenance, information and instruction obligations depending on the applicable characteristics.

8. Storage

Before the fitting components are assembled, they must be stored on a dry, protected and level surface.

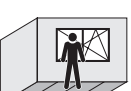
Declaration of symbols

	Max. Sash weight: x kg		Optional fittings
	Max. Sash size: x m ²		Size-dependent fittings depending on sash rebate width (FFB)
	Max. Sash rebate width (FFB): x mm		Size-dependent fittings depending on sash rebate height (FFH)
	Max. Sash rebate height (FFH): x mm		"TOP" marks the upper edge of the window.
	Constant handle height		Pot hinge version
	Central handle height		Rebate hinge version
	Turn sash (D)		Item for use on PVC-U windows
	Turn-tilt sash (DK)		Item for use on wooden windows with 12 mm airgap
	Turn/Turn-tilt double sash (D/DK-Stulp)		Item for use in wooden windows with 4 mm airgap and 18 mm overlap
	Parallel action		Item for use on aluminium windows
	Interior view		
	Exterior view		
	Basic set of fittings		

1

Packing key in the Winkhaus logistics system

The shipping units are configured in a way to enable you easy handling of our products in your works from small boxes to bulky pallets. For instance, we provide KLTs (small load carriers) in different sizes which are eco-friendly and facilitate logistics. The reusable packaging units, which can be stacked on a europallet, have a bar code and enable optimal stock organisation and easy transport to the relevant workstations. The packaging used for the products in question can be found on the corresponding product pages.



BL Goods packed in PE bags with bar code



KT Goods packed in cardboard boxes with bar code



BD Tied goods with barcode



K3 K3 Small cardboard box with bar code. Dim: 395 x 295 x 205 mm

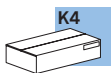

K4 K4 Big cardboard box with bar code. Dim: 595 x 395 x 205 mm



KK KK Small KLT (small load carrier) 4321. Dim: 400 x 300 x 214 mm with cover, bar code, sealed, stackable



GK GK Big KLT (small load carrier) 6412. Dim: 600 x 400 x 214 mm with cover, bar code, sealed, stackable

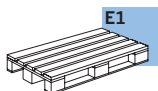

E1 E1 europallet with KLT Pallet size 800 x 1,200 mm

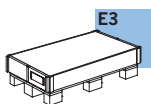

E3 E3 One-way pallet with cover box and bar code

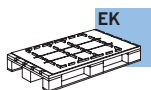

EK EK Europallet with KLT and fixing plate (avoids shifting of goods) Pallet size 800 x 1,200 mm



EA EA Europallet with frame and bar code Pallet size 800 x 1,200 mm

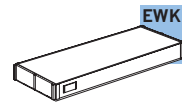

EWK EWK Disposable cardboard box E3, L6 or L7

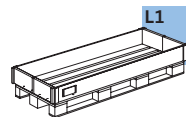

L1 L1 Reusable pallet for long goods with frame and bar code Pallet size 800 x 1,800 mm

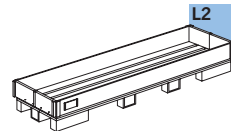

L2 L2 Reusable pallet II for long goods with frame and bar code Pallet size 800 x 2,400 mm

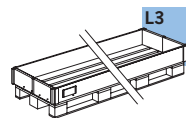

L3 L3 Reusable pallet III for long goods with frame and bar code Pallet size 800 x 3,500 mm

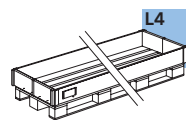

L4 L4 Reusable pallet IV for long goods with frame and bar code Pallet size 800 x 4,200 mm

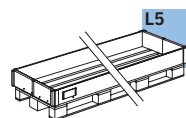

L5 L5 Reusable pallet V for long goods with frame and bar code Pallet size 800 x 6,500 mm

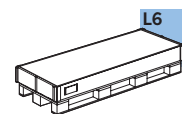

L6 L6 One-way pallet with cover box for long goods with bar code Pallet size 800 x 1,800 mm

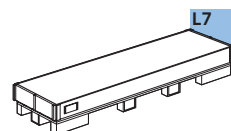

L7 L7 One-way pallet with cover box for long goods with bar code Pallet size 800 x 2,400 mm

Glossary

1

Code

AB.G.D	Drilling protection	GAVM	Locking drive rod activPilot, central handle position
ADS	Cover strip	GG	Handle set
ADP	Adapter	GK	Constant handle position
AKR	Automatic shootbolt	GRT.RB	Round arch set
AL...	Support plate		
ANS	Mounting element	HC	Timber windows, rebate version
AP.HH	Fitting punch, lever	HFG	Window Handle Case HFG
AP...SE	Adapter plate, activPilot Select	HT	Timber windows, pot hinge version
AS.DSL	Mini ventilation unit (turn position)		
AS.SBA	Mini vent keep		
ASP ER-A	End plate		
ASS AR	Connecting rail	IF	activPilot Topstar
AWDR	Stroke limiter		
BK	Balcony door catch	K.EL	Corner hinge cap
BK.KR	Catch bolt	K.FL	Sash hinge cover
BO	Catch bolt	K.SB	Shear hinge cap, timber
BS	Threshold	K.SK	Shear hinge insert cap
BST AP/FS	Fittings punch	K.SL	Shear hinge cover
		KB	Tilt hinge
		KBG	Tilt limiter
D	Backset	KE	Coupling element
DB	Turn limiter	KLB	Tilt hinge insert
DBG	Turn limiter	KR	Shootbolt
DFE	Dual function element	KUE-T1	Cable transition, separable
DL	Turn hinge insert		
DL...ET	Turn hinge, 1 piece	LE.B	Drill jig
DLW ERW	Turn hinge bracket	LE.FR	Milling jig
DML	Turn middle hinge	LE.N	Jig
DS	Window lock	LIN AP/FS	Ruler of fittings press
		LM-RG	Round handle
E	Corner drive	M	Interlocking rod
E1.A	Corner drive for studio windows	MK	Interlocking rod, extendable
E1.MSL	Corner drive with variable tilt device	MS.SO	Interlocking rod, double sash, keep top
E1.SBS	Corner drive for double-sash window		
EL	Corner hinges	MS.SU	Interlocking rod, double sash, keep bottom
ELK	Corner hinge cap	MSL.OS	Variable tilt device top rod
FBP	Window limiter	NML	Groove centre position
FH ...	Sash lifter		
FL	Sash hinges	OBV	Opening limiter
FL...PADS	Sash hinge, PADS	OS	Top rod
FL...PAD/ PADM	Sash hinge PAD/PADM	OS...PA...	Top rod, PADK
FL...PADK	Sash hinge, PADK	OS. ...E	Top rod (turn before tilt)
FLK	Sash hinge cover	OS.A	Screw clip
FLS.SE	Sash hinge rail, activPilot Select		
FSA	Fail safe device FSA	PA	Parallel action
FSF	Fail safe device FSF	PAD	Parallel action, turn
FSR	Rebate shear	PADK	Parallel action, turn-tilt
FT	Spacer		
GAK	Drive rod, constant handle position	RA.DB.SE	Frame connection turn limiter
GAKA	Drive rod, constant handle position, lockable	RT.DFE-TFE	Frame part, dual/triple function element
GAM	Drive rod, central handle position	RT.DFE-TFE.S	Frame part, dual/triple function element, double-sash windows
GAMA	Drive rod, central handle position, lockable		
GASK	Double sash drive rod, constant handle position	RT.MSL	Frame part, variable tilt device
GASM	Double sash drive rod, central handle position		

1

		Item designation	
S.FL	Sash hinge plug	...LS	Fitting direction left
SA	Shootbolt keeps	...RS	Fitting direction right
SA.IF	Shear activPilot Topstar aluminium	...AGR	anthracite grey (similar to RAL 7016)
SB SZV	Keep, claw bolt	...BR	brown (similar to RAL 8019)
SBA...	Keep, contact pressure	...BZ-AM	bronze - antique brass
SBA...T	Mini vent keep	...BZ-CU	bronze - coppery
SBK	Security tilt keep	...BZ-RB	bronze - red brown
SBK...E	Tilt keep (tilt before turn)	...CW	cream white (similar to RAL 9001)
SBK...PA	Tilt keep (with slider), PADK	...EV1	anodised silver
SBK...SP	Security tilt keep with gap locking device	...F1	silver coloured
		...F1-elox	(similar to F1) anodised silver
SBS...	Security keep	...F3	gold coloured
SBS...PA	Security keep, PADK	...F3-MG	gold mat
SBS...PAB	Security keep PAB, PADK	...F9	titanium coloured
SBS...PAD	Security keep PAD	...LBR	clay brown
SC	Shear, rebate hinge	...PW	pearl white (similar to RAL 1013)
SC...A	Shear studio window	...SG	silver-grey (similar to RAL 7001)
SC...E	Shear (tilt before turn)	...SGB	grey (similar to RAL 9006)
SC...PA...	Shear, PADK	...SGR	grey (similar to RAL 7037)
SC...PAD...	Shear PAD	...SL	silver look (zinc galvanised)
SCO	Shear, without turn restriction	...SW	jet black
SE	activPilot Select	...WS	white (similar to RAL 9016)
SH...T	Shear, pot hinge		
SH.IF	Shear activPilot Topstar Timber		
SK.IF	Shear activPilot Topstar PVC-U		
SL	Shear hinge		
SL.HC	Shear hinge, timber rebate hinge		
SLK	Shear hinge cap, rebate hinge		
SNH	Faceplate fastener		
SP R	Faceplate		
SR	Control unit SR		
SZP	Geared cover plate		
TFE	Triple function element		
UEB	Overlap		
UF	Packer		
V	Distance between locking points		
VBST	Connection piece		
V.AK	Extension rod		
VK.AK	Extension rod, extendable		
VS R	Connection rod		
VS RB	Connection rod round-arch window		
XL	Components from activPilot Giant range		
ZSR	Additional shear		
ZSRE	Additional shear (tilt before turn)		
ZSS	Anti-slam device		
ZV...	Claw bolt		
ZV.RT	Claw bolt, frame part		

Guidelines for using application diagrams

- Prerequisites:
 - When fixing load-bearing components, please consider the TBDK guidelines. The tractive forces shown in the table have to be achieved. The suitable proof must be provided by the window manufacturer.
 - The values given here apply to the shear hinge. An extra test of the corner hinge is not necessary in case the fixing situation is identical to that of the shear hinge.

m [kg]	F [N]
50	1400
60	1650
70	1900
80	2200
90	2450
100	2710
110	3000
120	3250
130	3525

- Please control:
 - Are window dimensions within the range highlighted in grey?
 - Is the intersection point to be determined located to the left of the limiting curve of the glass weight?

m [kg] = max. sash weight in kg
 F [N] = tractive force on the shear hinge in N

• Example:

Intended window dimensions:

- FFB = 1.100 mm
- FFH = 1.800 mm
- GG = 40 kg/m² (corresponds to the cyan curve)

The intersection point "S" is located in the area highlighted in grey and to the left of the limiting curve of the filling weight (GG = 40 kg/m²), i. e. in the permitted area.

• General notes:

On the establishment of application diagrams, the following values were considered:

- Glass weight GG - 2.5 kg/m² per mm of glass thickness
- Profile weight - 3.25 kg/RM

Please find more detailed information on the website <http://www.ift-service.de/awd/ift/start.faces> as well as on <http://www.fvsb.de/ggsb/richtlinien.asp>.



activPilot Topstar

Application diagram for ascertaining the admissible sash sizes

Max. Sash weight 130 kg

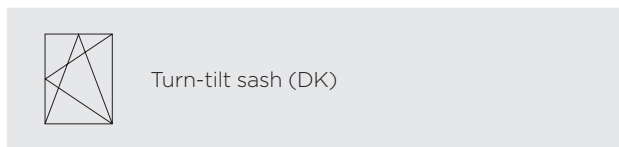
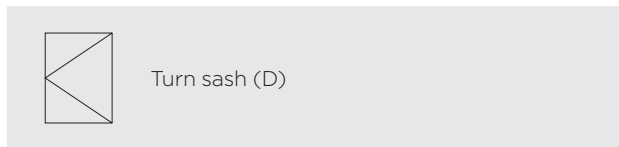
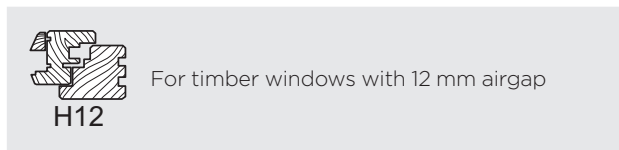

Width-to-height ratio and additional load

Value calculated without additional load for a width-to-height ratio of 2:1. The application graphs have been calculated without additional loads. Please consult your authorised contact person for further information on how to calculate the maximum permissible window sash format with an additional load.

Advice for use

The application range permitted for using Winkhaus fitting is highlighted in grey in the application graphs. However, it is essential not to use the entire grey-highlighted section, but only those parts which are on the left-hand side of the curve for the respective GG filling weight.

Application range

The respective overall fitting must be selected from the original Winkhaus activPilot fitting components range. Winkhaus accepts no liability if non-original or unauthorised system accessory parts are used.

- Min. Sash rebate width 380 mm
- Max. Sash rebate width 1725 mm
- From 1475 mm sash rebate width with additional shear ZSR
- Min. Sash rebate height 230 mm
- Max. Sash rebate height 2800 mm
- Max. Sash size 3 m²
- Ratio between sash rebate width: sash rebate height ≤ 2:1
- Airgap at bottom side 12 +1 mm

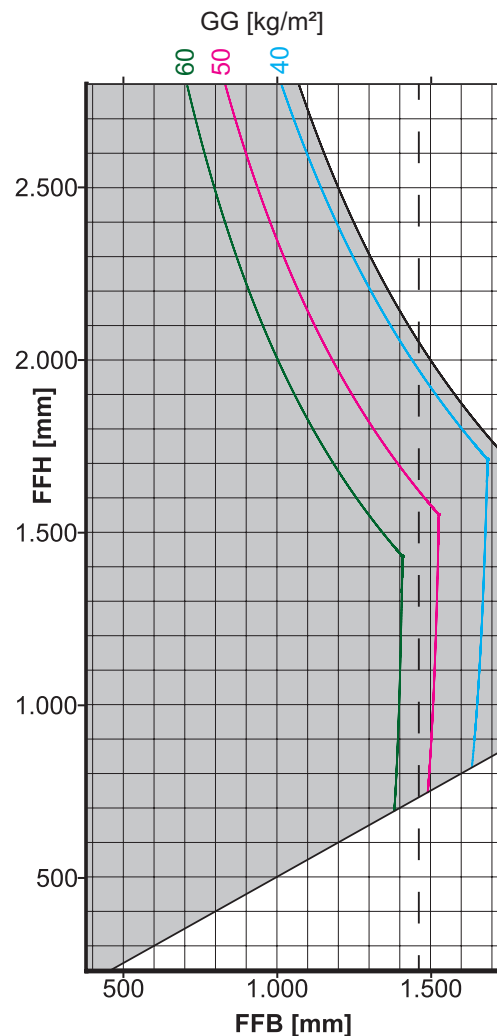

AWD_01.50_NR30_DK_130 kg_ohne_Zusatzlast_2_m

Abbreviations

- FFB = Sash rebate width [mm]
- FFH = Sash rebate height [mm]
- GG = Glass weight per square metre [kg/m²]
- ZSR = Additional shear
(section on right of interrupted line)











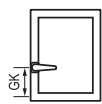

Important: The screw connections of the load-bearing fitting components, such as corner, shear and sash hinges must be performed according to the TBDK guidelines. Adapt the drilling diameter for the fixing screws, the screw diameter and the screw length to the load situation.

Overview of min. dimensions for drive rods D = 15.5 mm

The following overview shows the applications supported by top corner drives. Use depends on the variant "tilt & turn" or "turn double sash", and the window size. Depending on the application, other elements can be used as alternatives to top corner drives. If the sash rebate height is smaller than 750 mm, the airgap in the shear area must be 12 mm at least.

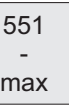







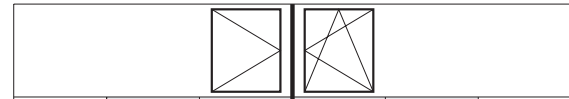

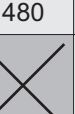

Turn-tilt type, constant, single sash

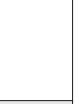

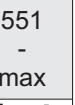
				
	380 - 480	481 - 550	551 - max	
230 - 325				
326 - 420				
421 - max				







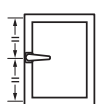

Turn/Turn-tilt double sash type, constant



					
	481 - max	280 - 480	480 - 550	551 - max	
230 - 450					230 - 450
451 - 545					451 - max
546 - max					

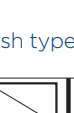

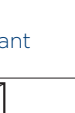
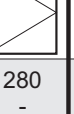

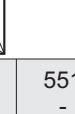



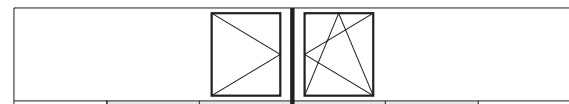









Turn-tilt type, central, single sash

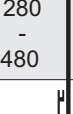

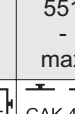
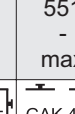
				
	380 - 480	481 - 550	551 - max	
230 - 325		 GAK 465 G = 114	 GAK 465 G = 114	
326 - 510				
511 - max				

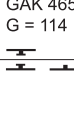
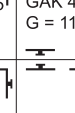
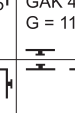
Turn/Turn-tilt double sash type, central

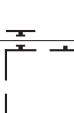

					
	481 - max	280 - 480	480 - 550	551 - max	
230 - 410			 GAK 465 G = 114	 GAK 465 G = 114	230 - 410
411 - 560					411 - 560
561 - 710					561 - max
711 - 980					
981 - max					

E1 | E1.SE | E3 | KR



1

Overview of min. dimensions for drive rods D = 7.5 mm





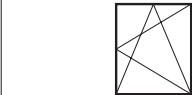

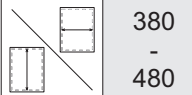
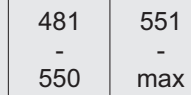
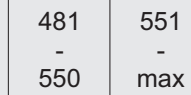
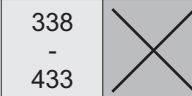
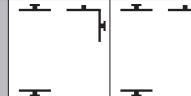
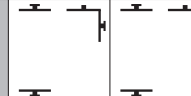
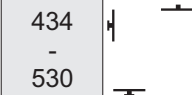
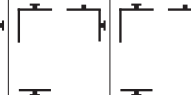
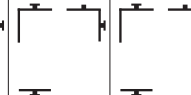
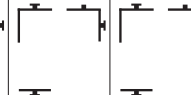
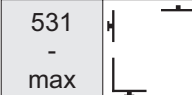
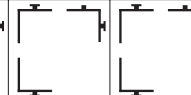
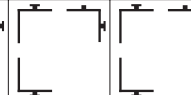
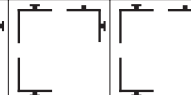









The following overview shows the applications supported by top corner drives. Use depends on the variant "tilt & turn" or "turn double sash", and the window size. Depending on the application, other elements can be used as alternatives to top corner drives. If the sash rebate height is smaller than 750 mm, the airgap in the shear area must be 12 mm at least.

Turn-tilt type, constant, single sash









		380 - 480	481 - 550	551 - max
		X		
338 - 433		X		
434 - 530				
531 - max				



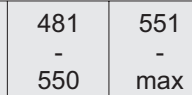
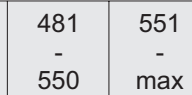
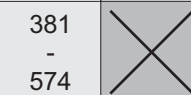
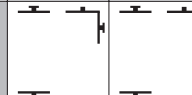
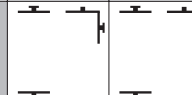
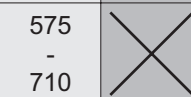

Turn/Turn-tilt double sash type, constant

					
	481 - max	280 - 480	480 - 550	551 - max	
338 - 433					338 - 433
434 - 530					434 - 530
531 - max					531 - max

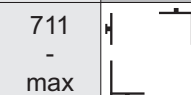
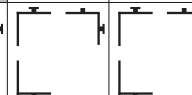
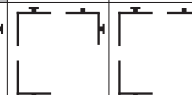
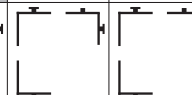





















Turn-tilt type, central, single sash



		380 - 480	481 - 550	551 - max
		X		
381 - 574		X		
575 - 710		X		
711 - max				

Turn/Turn-tilt double sash type, central



					
	481 - max	280 - 480	480 - 550	551 - max	
381 - 410					381 - 410
411 - 574					411 - 574
575 - 710					575 - 710
711 - 980		GASM 1050			711 - 980
981 - max		X			981 - max

Overview of max. dimensions for drive rods D = 15.5 and 7.5 mm



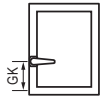

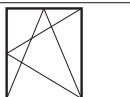
This overview shows how the gear side is designed when tall windows up to 2,725/2,800 mm are involved. The maximum sash height depends on the position of the window handle, central or constant.

Turn-tilt type, constant, single sash



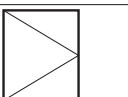
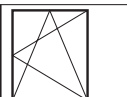



	
	min - max*
2226 - 2475	MK.250-1 + GAK.2225-...
2476 - 2725	MK.500-1 + GAK.2225-...

Turn/Turn-tilt double sash type, constant

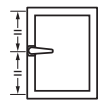

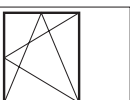

			
	min - max*	min - max*	
2226 - 2475	MS.SO.250-1 + GASK.2225-...	MK.250-1 + GAK.2225-...	2226 - 2475
2476 - 2725	MS.SO.500-1 + GASK.2225-...	MK.500-1 + GAK.2225-...	2476 - 2725

Turn-tilt type, central, single sash

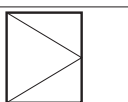
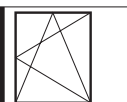

	
	min - max*
2301 - 2800	MK.250-1 + GAM.2300-3 + MK.250-1

Turn/Turn-tilt double sash type, central

			
	min - max*	min - max*	
2301 - 2800	MS.SO.250-1 + GASM.2300-3 + MS.SU.250-1	MK.250-1 + GAM.2300-3 + MK.250-1	2301 - 2800

* Please observe the "Diagrams to determine permissible sash sizes"!

Explanation of fitting lists

The fitting lists consist of two pages each. The first page shows the visual fitting composition whereas the second page includes a possible fitting configuration in the shape of a tabular list.



The processing details regarding burglary-resistant window units can be gathered from the DIN EN 1627 - 1630 system documentation. The lists of fittings in this catalogue are merely intended to give application examples. Please get in touch with your Winkhaus contact partner.

Our register system allows you to quickly allocate the listed component to the item in the fitting overview drawing.

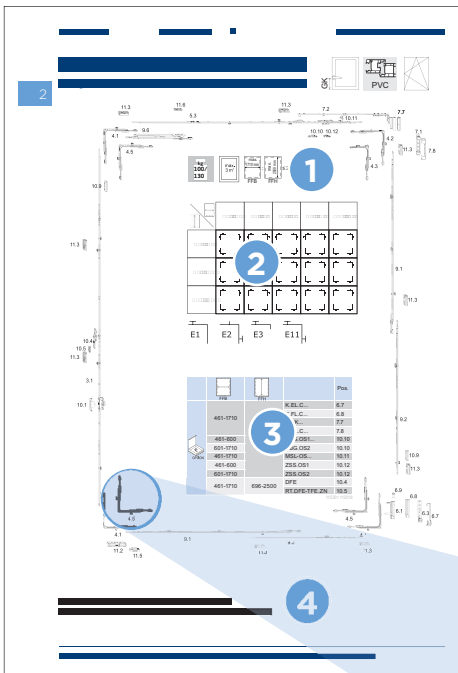

This is a tabular list of fittings corresponding to the overview drawing. The table has columns for:

- Part name (e.g., 465-1710, 485-600, 485-1770).
- Dimensions (e.g., 113, 114, 115, 116).
- Part number (e.g., 465-1710, 485-600, 485-1770).
- Material (e.g., AL, PVC).
- Color (e.g., RAL, 9011, 9005).
- Application range (e.g., 113, 114, 115, 116).

- 1** Maximum application ranges
- 2** Overview min./max. dimensions
- 3** Optional components
- 4** Applied distance between locking points

4.5

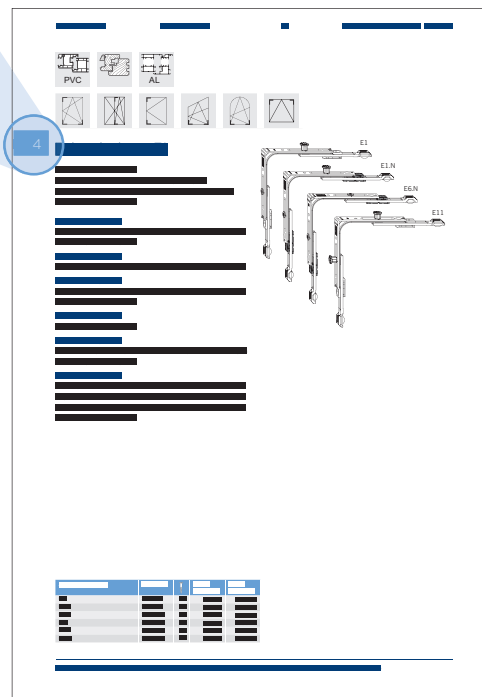

Explanation of sub-areas

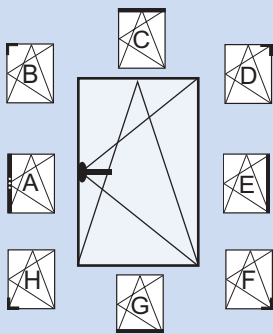

For the tabular list of fitting parts the window or door sash is divided into eight sections (A-H). The sections include the four sides and four corners of the unit.

The window or door unit is divided into 8 sections (4 corners, 4 sides). In order to determine a complete fitting set of a certain sash size, it is necessary to ascertain items from all the sections (1). In each subarea (1), the articles to be used (4) and their item numbers (5) can be read, depending on the application area FFB (2) and FFH (3). The frame part types (6) are also supplemented with their position number (7) and quantity (8). The item numbers refer to the position of the component within the fitting overview (page 1).

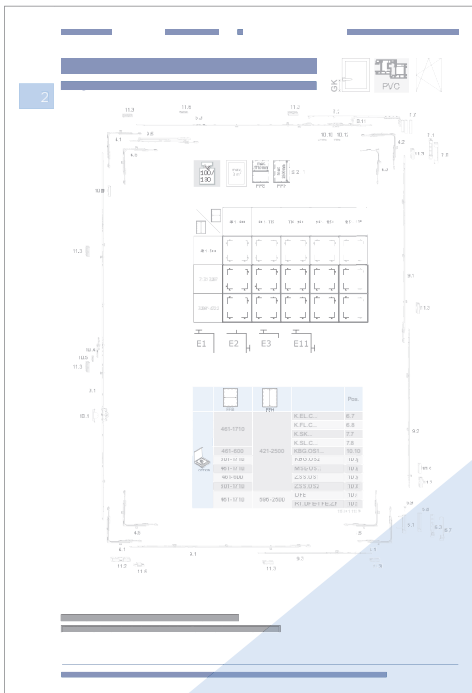

	2	3	4	5	4	5	4	5	6	7	8	
	FFB	FFH		Pos.		Pos.		Pos.		Pos.		
1	9	461-1710	421-2500	AB.G.D.15,5	10.1	AL D...	10.9					
			461-920	421-460	GAK.465	3.1						
			461-1160	461-580	GAK.710	3.1						
			461-1390	581-695	GAK.830-1	3.1				SBS.K...	11.3	1x
			461-1700	696-850	GAK.945-1	3.1				SBS.K...	11.3	1x
				851-1075	GAK.1100-1	3.1				SBS.K...	11.3	1x
				1076-1325	GAK.1325-2	3.1				SBS.K...	11.3	2x
				1326-1525	GAK.1550-2	3.1				SBS.K...	11.3	3x
				1526-1775	GAK.1775-2	3.1				SBS.K...	11.3	2x
				1776-2000	GAK.2000-2	3.1				SBS.K...	11.3	2x
	2001-2225	GAK.2225-2	3.1				SBS.K...	11.3	2x			
	2226-2475	GAK.2225-2	3.1	MK.250-1	9.1		SBS.K...	11.3	2x			
	2476-2500	GAK.2225-2	3.1	MK.500-1	9.1		SBS.K...	11.3	3x			
	461-1160	421-580	E11	4.5				SBS.K...	11.3	2x		
	461-1710	581-2500	E1	4.1				SBS.K...	11.3	1x		

- 1 Section (A-H)
- 2 Sash rebate width (FFB) (application ranges on items level)
- 3 Sash rebate height (FFH) (application ranges on items level)
- 4 Items to be used
- 5 Position number of items
- 6 Type of frame part
- 7 Position number of frame parts
- 8 Number of frame parts
- 9 **i** marks a line with items that are always used, regardless of size

Lists of Fittings

Turn fitting system – constant handle position Basic equipment	26
Turn-tilt fitting system – central handle position Basic equipment	28
Turn-tilt fitting system – constant handle position Suitable for burglary-resistant windows RC2 / RC2 N	30
Turn-tilt fitting system – central handle position Suitable for burglary-resistant windows RC2 / RC2 N	34
Turn double sash fitting system – constant handle position 9 mm and 13 mm groove centre position with circumferential locking points	38
Turn double sash fitting system – central handle position 9 mm and 13 mm groove centre position with circumferential locking points	40
Turn double sash fitting system – constant handle position Basic equipment with claw bolt	42
Turn double sash fitting system – central handle position Basic equipment with claw bolt	44
Turn double sash fitting system – constant handle position Suitable for burglary-resistant windows RC2 / RC2 N	46
Turn double sash fitting system – central handle position Suitable for burglary-resistant windows RC2 / RC2 N	50
Turn-tilt fitting system – constant handle position Basic equipment – Tilt before turn	54
Turn-tilt fitting system – central handle position Basic equipment – Tilt before turn	56
Tilt fanlight Basic equipment	58

Turn-tilt fitting – constant handle position

Basic equipment

9 mm and 13 mm groove centre position

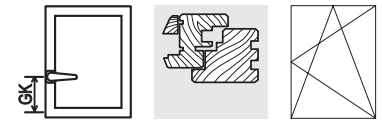

2

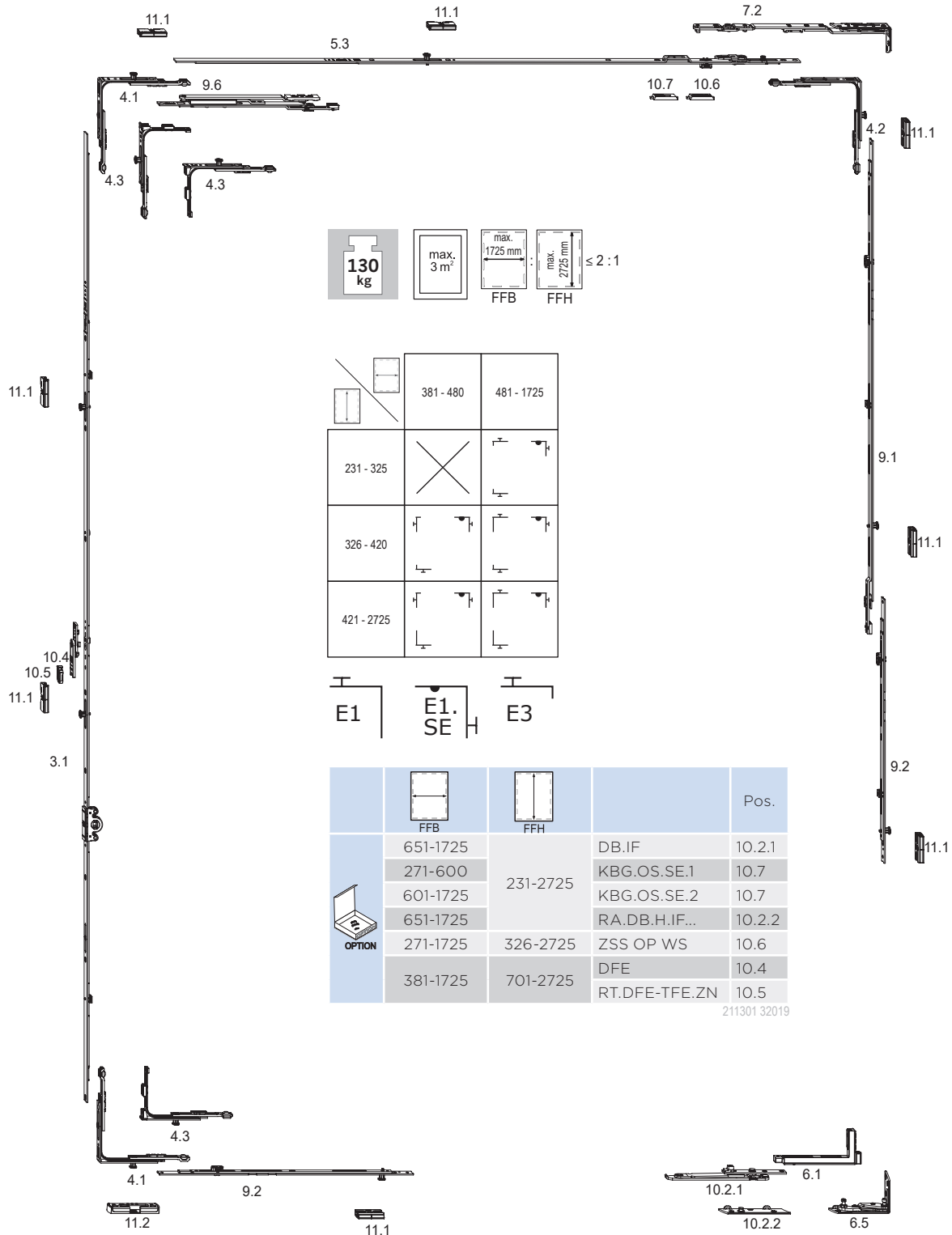

The shown distance between locking points is 1000 mm.









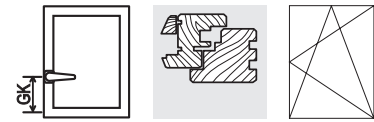

The locking distance to be used is the responsibility of the window manufacturer.

Turn-tilt fitting – constant handle position

Basic equipment

9 mm and 13 mm groove centre position



				Pos.		Pos.		Pos.		Pos.	
	481-650	231-325	GAK.465	3.1			GK = 114				
	381-840	326-420	GAK.465	3.1			GK = 114				
	381-920	421-460	GAK.465	3.1			GK = 210				
	381-1400	461-700	GAK.710	3.1			GK = 210				
	381-1700	701-850	GAK.945-1	3.1			GK = 260		SBA.H...	11.1	1x
	381-1725	851-1100	GAK.1100-1	3.1			GK = 375		SBA.H...	11.1	1x
		1101-1325	GAK.1325-1	3.1			GK = 550		SBA.H...	11.1	1x
		1326-1550	GAK.1550-1	3.1			GK = 550		SBA.H...	11.1	1x
		1551-1775	GAK.1775-2	3.1			GK = 550		SBA.H...	11.1	2x
		1776-2000	GAK.2000-2	3.1			GK = 1050		SBA.H...	11.1	2x
2001-2225		GAK.2225-2	3.1			GK = 1050		SBA.H...	11.1	2x	
2226-2475	GAK.2225-2	3.1	MK.250-1	9.1		GK = 1050		SBA.H...	11.1	3x	
2476-2725	GAK.2225-2	3.1	MK.500-1	9.1		GK = 1050		SBA.H...	11.1	3x	
	381-480	326-2725	E3	4.3					SBA.H...	11.1	1x
	481-650	231-325	E3	4.3					SBA.H...	11.1	1x
	481-1725	326-2725	E1	4.1					SBA.H...	11.1	1x
	381-550	326-2725	OS.SE.550	5.3							
	481-550	231-325	OS.SE.550	5.3							
	551-800	231-2725	OS.SE.800	5.3							
	801-1025		OS.SE.1025-1	5.3					SBA.H...	11.1	1x
	1026-1250		OS.SE.1250-1	5.3					SBA.H...	11.1	1x
	1251-1475		OS.SE.1250-1	5.3	MK.250-0	9.1			SBA.H...	11.1	1x
	1476-1500		OS.SE.1025-1	5.3	MK.250-1	9.1	ZSR SL	9.6	SBA.H...	11.1	2x
1501-1725	OS.SE.1250-1	5.3	MK.250-1	9.1	ZSR SL	9.6	SBA.H...	11.1	2x		
	381-1725	326-2725	E1.SE	4.2	SH.IF-N...	7.2			SBA.H...	11.1	1x
	481-650	231-325	E1.SE	4.2	SH.IF-N...	7.2			SBA.H...	11.1	1x
	381-1725	1061-1485	M.500-1	9.2					SBA.H...	11.1	1x
		1486-1735	M.750-1	9.2					SBA.H...	11.1	1x
		1736-2235	MK.750-1	9.1	M.500-1	9.2			SBA.H...	11.1	2x
		2236-2485	MK.750-1	9.1	M.750-1	9.2			SBA.H...	11.1	2x
		2486-2725	MK.750-1	9.1	MK.750-1	9.1	M.500-1	9.2	SBA.H...	11.1	3x
	481-650	231-325	FL.IF-N...	6.1	EL.H.IF-N...	6.5					
	381-1725	326-2725	FL.IF-N...	6.1	EL.H.IF-N...	6.5					
	1041-1450	231-2725	M.500-1	9.2					SBA.H...	11.1	1x
	1451-1725		M.750-1	9.2					SBA.H...	11.1	1x
	381-840	326-420	E3	4.3					SBK.H...	11.2	1x
	381-1725	421-2725	E1	4.1					SBK.H...	11.2	1x
	481-650	231-325	E3	4.3					SBK.H...	11.2	1x

 marks a line with items that are always used, regardless of size

Turn-tilt fitting – central handle position

Basic equipment

9 mm and 13 mm groove centre position

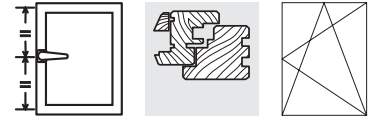

2

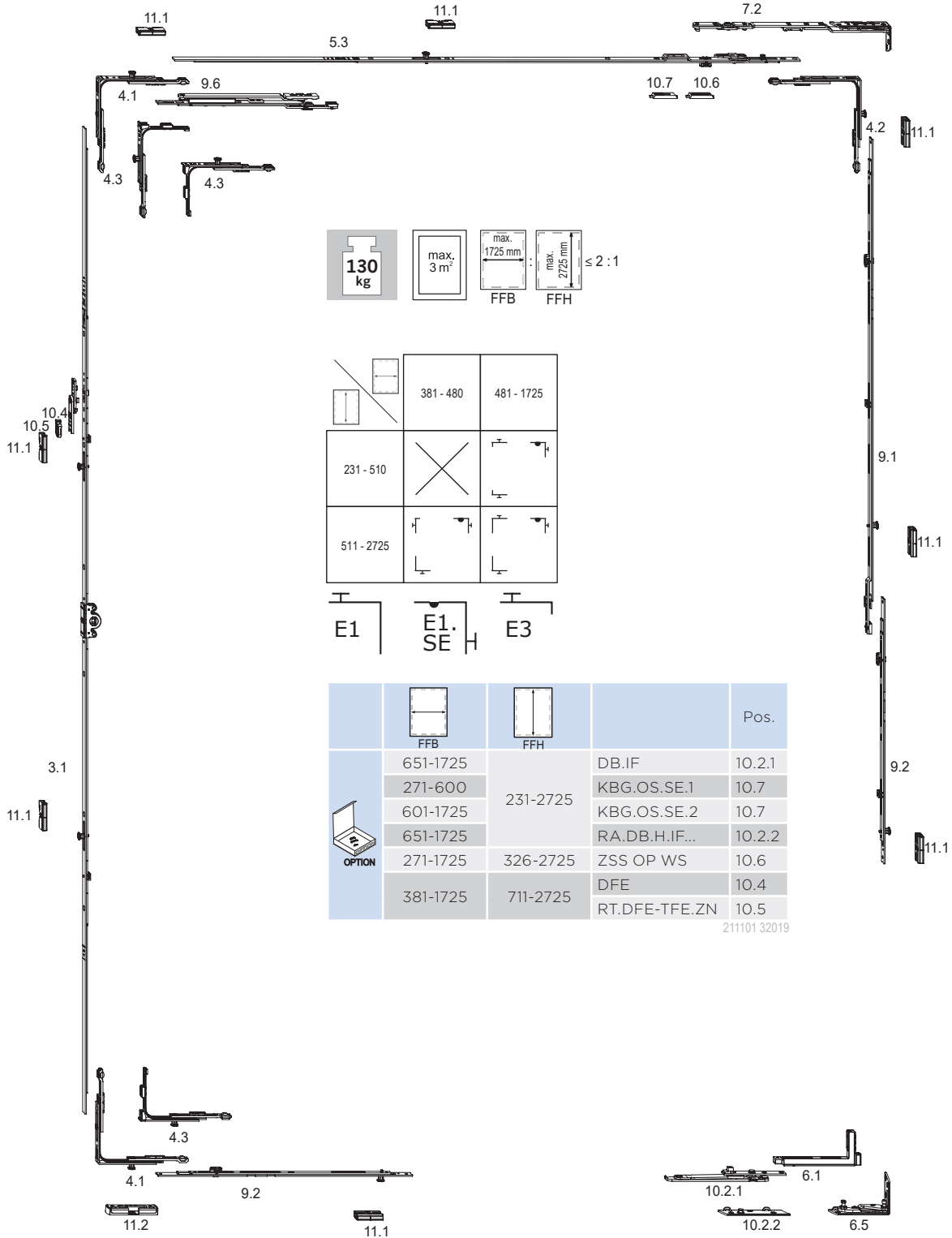

The shown distance between locking points is 1000 mm.

The locking distance to be used is the responsibility of the window manufacturer.











Turn-tilt fitting – central handle position

Basic equipment

9 mm and 13 mm groove centre position



2

				Pos.		Pos.		Pos.		Pos.		
	481-650	231-325	GAK.465	3.1			GK = 114					
	481-1020	326-510	GAM.800	3.1								
	381-1420	511-710	GAM.800	3.1								
	381-1725		231-2725	711-980	3.1					SBA.H...	11.1	1x
				981-1400	3.1					SBA.H...	11.1	1x
				1401-1800	3.1					SBA.H...	11.1	2x
				1801-2300	3.1					SBA.H...	11.1	3x
			2301-2725	3.1	MK.250-1	9.1	MK.250-1	9.1	SBA.H...	11.1	5x	
	381-480	511-2725	E3	4.3					SBA.H...	11.1	1x	
	481-1020	231-510	E3	4.3					SBA.H...	11.1	1x	
	481-1725	511-2725	E1	4.1					SBA.H...	11.1	1x	
	381-550	511-2725	OS.SE.550	5.3								
	481-550	231-510	OS.SE.550	5.3								
	551-800	231-2725	OS.SE.800	5.3								
	801-1025		OS.SE.1025-1	5.3					SBA.H...	11.1	1x	
	1026-1250		OS.SE.1250-1	5.3					SBA.H...	11.1	1x	
	1251-1475		OS.SE.1250-1	5.3	MK.250-0	9.1			SBA.H...	11.1	1x	
	1476-1500		OS.SE.1025-1	5.3	MK.250-1	9.1	ZSR SL	9.6	SBA.H...	11.1	2x	
1501-1725	OS.SE.1250-1	5.3	MK.250-1	9.1	ZSR SL	9.6	SBA.H...	11.1	2x			
	381-1725	511-2725	E1.SE	4.2	SH.IF-N...	7.2			SBA.H...	11.1	1x	
	481-1020	231-510	E1.SE	4.2	SH.IF-N...	7.2			SBA.H...	11.1	1x	
	381-1725	1061-1485	M.500-1	9.2					SBA.H...	11.1	1x	
		1486-1735	M.750-1	9.2					SBA.H...	11.1	1x	
		1736-2235	MK.750-1	9.1	M.500-1	9.2			SBA.H...	11.1	2x	
		2236-2485	MK.750-1	9.1	M.750-1	9.2			SBA.H...	11.1	2x	
		2486-2725	MK.750-1	9.1	MK.750-1	9.1	M.500-1	9.2	SBA.H...	11.1	3x	
	481-1020	231-510	FL.IF-N...	6.1	EL.H.IF-N...	6.5						
	381-1725	511-2725	FL.IF-N...	6.1	EL.H.IF-N...	6.5						
	1041-1450	231-2725	M.500-1	9.2					SBA.H...	11.1	1x	
	1451-1725		M.750-1	9.2					SBA.H...	11.1	1x	
	381-1725	511-2725	E1	4.1					SBK.H...	11.2	1x	
	481-1020	231-510	E3	4.3					SBK.H...	11.2	1x	

 marks a line with items that are always used, regardless of size

Turn-tilt fitting – constant handle position

Suitable for burglary-resistant windows RC2 / RC2 N

- from 24 mm frame rebate depth - 13 mm groove centre position

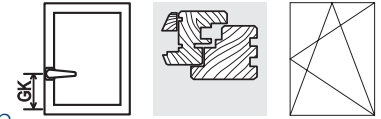

2

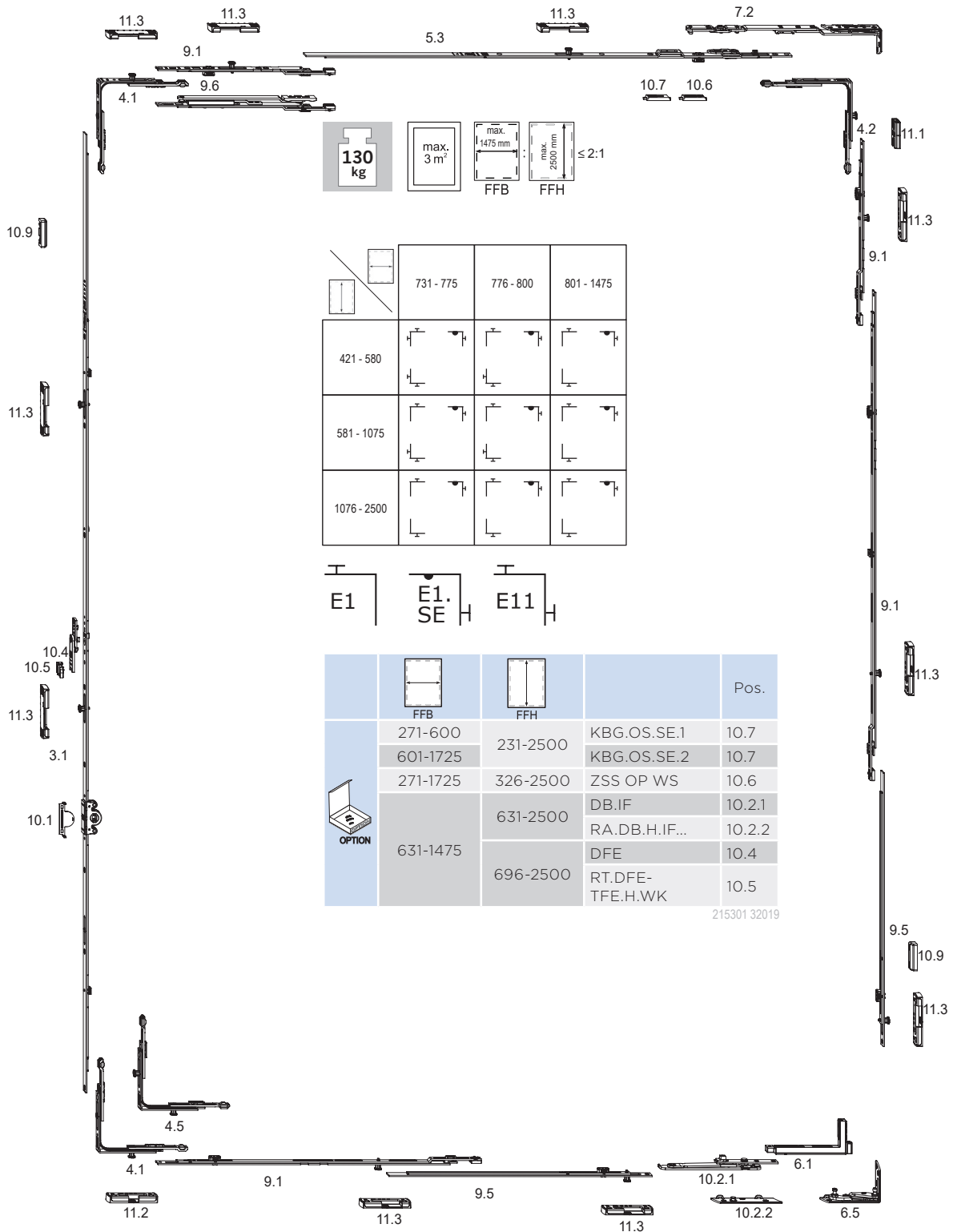

The shown distance between locking points is 1000 mm.









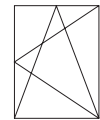
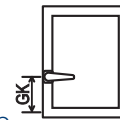

The locking distance to be used is the responsibility of the window manufacturer.

Turn-tilt fitting – constant handle position

Suitable for burglary-resistant windows RC2 / RC2 N

- from 24 mm frame rebate depth - 13 mm groove centre position



				Pos.		Pos.		Pos.		Pos.		
	i 631-1475	631-2500	AB.G.D.15,5	10.1	AL D...	10.9						
	631-1390	631-695	GAK.830-1	3.1			GK = 260		SBS.H...	11.3	1x	
	631-1475	696-850	GAK.945-1	3.1				GK = 260		SBS.H...	11.3	1x
		851-1075	GAK.1100-1	3.1				GK = 375		SBS.H...	11.3	1x
		1076-1325	GAK.1325-1	3.1				GK = 550		SBS.H...	11.3	1x
		1326-1525	GAK.1550-2	3.1				GK = 550		SBS.H...	11.3	3x
		1526-1775	GAK.1775-2	3.1				GK = 550		SBS.H...	11.3	2x
		1776-2000	GAK.2000-2	3.1				GK = 1050		SBS.H...	11.3	2x
		2001-2225	GAK.2225-2	3.1				GK = 1050		SBS.H...	11.3	2x
		2226-2475	GAK.2225-2	3.1	MK.250-1	9.1		GK = 1050		SBS.H...	11.3	3x
2476-2500	GAK.2225-2	3.1	MK.500-1	9.1		GK = 1050		SBS.H...	11.3	3x		
	631-1475	631-2500	E1	4.1					SBS.H...	11.3	1x	
	631-730	631-2500	OS.SE.550	5.3	MK.150-1	9.8			SBS.H...	11.3	1x	
	731-775		OS.SE.550	5.3	MK.250-1	9.1			SBS.H...	11.3	1x	
	776-1025		OS.SE.1025-1	5.3					SBS.H...	11.3	1x	
	1026-1275		OS.SE.1025-1	5.3	MK.250-1	9.1			SBS.H...	11.3	2x	
	1276-1475		OS.SE.1025-1	5.3	MK.250-1	9.1	ZSR SL	9.6	SBS.H...	11.3	2x	
	631-1475	631-2500	E1.SE	4.2	SH.IF-N...	7.2			SBA.H...	11.1	1x	
	i 631-1475	631-2500	AL D...	10.9								
	631-1270	631-635	M.250-1	9.2					SBS.H...	11.3	1x	
	631-1475	636-1000	MK.250-1	9.1	M.250-1	9.2			SBS.H...	11.3	2x	
		1001-1200	MK.250-1	9.1	M.500-1	9.2			SBS.H...	11.3	2x	
		1201-1550	MK.250-1	9.1	M.750-1	9.2			SBS.H...	11.3	2x	
		1551-1720	MK.250-1	9.1	MK.500-1	9.1	V.AK.450-1	9.5	SBS.H...	11.3	3x	
		1721-1970	MK.250-1	9.1	MK.750-1	9.1	V.AK.450-1	9.5	SBS.H...	11.3	3x	
		1971-2220	MK.250-1	9.1	MK.500-1	9.1	MK.500-1	9.1	SBS.H...	11.3	4x	
			V.AK.450-1	9.5								
		2221-2470	MK.250-1	9.1	MK.500-1	9.1	MK.750-1	9.1	SBS.H...	11.3	4x	
	V.AK.450-1	9.5										
2471-2500	MK.250-1	9.1	MK.500-1	9.1	MK.500-1	9.1	SBS.H...	11.3	5x			
	MK.500-1	9.1	V.AK.450-1	9.5								
	631-1475	631-2500	FL.IF-N...	6.1	EL.H.IF-N...	6.5						
	631-850	631-2500	V.AK.450-1	9.5					SBS.H...	11.3	1x	
	851-1100		V.AK.450-1	9.5	MK.250-1	9.1			SBS.H...	11.3	2x	
	1101-1360		V.AK.450-1	9.5	MK.500-1	9.1			SBS.H...	11.3	2x	
	1361-1475		V.AK.450-1	9.5	MK.750-1	9.1			SBS.H...	11.3	2x	
	631-800	631-1075	E11	4.5					SBS.H...	11.3	1x	
	631-1475	1076-2500	E1	4.1					SBK.H...	11.2	1x	
	801-1475	631-1075	E1	4.1					SBK.H...	11.2	1x	

i marks a line with items that are always used, regardless of size

2

Turn-tilt fitting – constant handle position

Suitable for burglary-resistant windows RC2 / RC2 N
 - from 29 mm frame rebate depth - 13 mm groove centre position

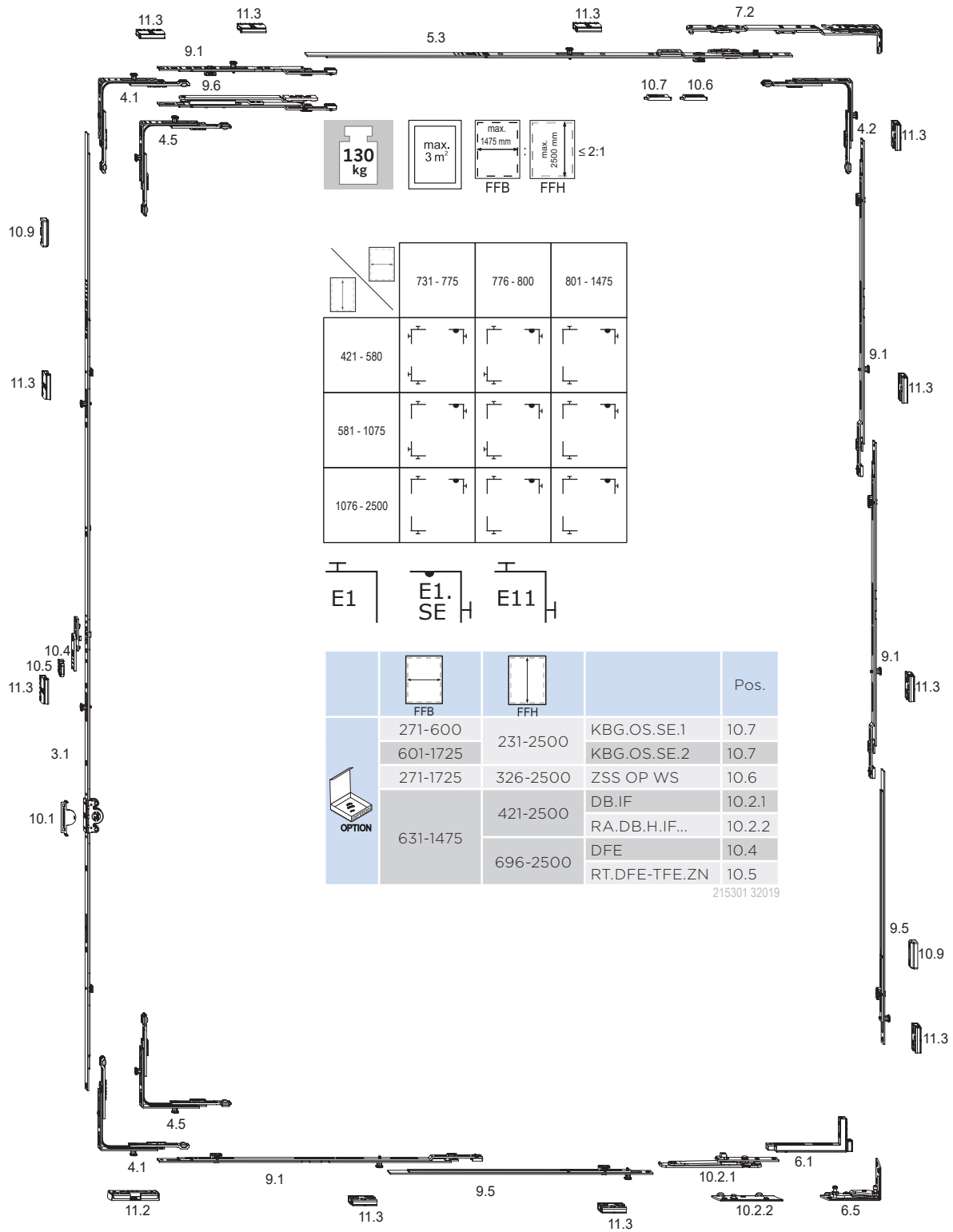

The shown distance between locking points is 1000 mm.
 The locking distance to be used is the responsibility of the window manufacturer.









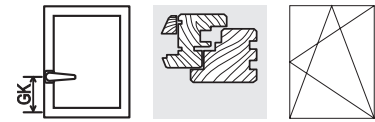

Turn-tilt fitting – constant handle position

Suitable for burglary-resistant windows RC2 / RC2 N

- from 29 mm frame rebate depth - 13 mm groove centre

position



				Pos.		Pos.		Pos.		Pos.	
	i 631-1475	421-2500	AB.G.D.15,5	10.1	AL D...	10.9					
	631-920	421-460	GAK.465	3.1			GK = 210				
	631-1160	461-580	GAK.710	3.1			GK = 210				
	631-1390	581-695	GAK.830-1	3.1			GK = 260		SBS.H...	11.3	1x
	631-1475	696-850	GAK.945-1	3.1			GK = 260		SBS.H...	11.3	1x
		851-1075	GAK.1100-1	3.1			GK = 375		SBS.H...	11.3	1x
		1076-1325	GAK.1325-1	3.1			GK = 550		SBS.H...	11.3	1x
		1326-1525	GAK.1550-2	3.1			GK = 550		SBS.H...	11.3	3x
		1526-1775	GAK.1775-2	3.1			GK = 550		SBS.H...	11.3	2x
		1776-2000	GAK.2000-2	3.1			GK = 1050		SBS.H...	11.3	2x
		2001-2225	GAK.2225-2	3.1			GK = 1050		SBS.H...	11.3	2x
		2226-2475	GAK.2225-2	3.1	MK.250-1	9.1	GK = 1050		SBS.H...	11.3	3x
2476-2500	GAK.2225-2	3.1	MK.500-1	9.1	GK = 1050		SBS.H...	11.3	3x		
	631-775	421-580	E11	4.5					SBS.H...	11.3	2x
	631-1475	581-2500	E1	4.1					SBS.H...	11.3	1x
	776-1160	421-580	E1	4.1					SBS.H...	11.3	1x
	631-730	421-2500	OS.SE.550	5.3	MK.150-1	9.8			SBS.H...	11.3	1x
	731-775		OS.SE.550	5.3	MK.250-1	9.1			SBS.H...	11.3	1x
	776-1025		OS.SE.1025-1	5.3					SBS.H...	11.3	1x
	1026-1275		OS.SE.1025-1	5.3	MK.250-1	9.1			SBS.H...	11.3	2x
	1276-1475		OS.SE.1025-1	5.3	MK.250-1	9.1	ZSR SL	9.6	SBS.H...	11.3	2x
	631-1475	421-2500	E1.SE	4.2	SH.IF-N...	7.2			SBS.H...	11.3	1x
	i 631-1475	421-2500	AL D...	10.9							
	631-1170	421-585	M.250-1	9.2					SBS.H...	11.3	1x
	631-1475	586-1000	M.500-1	9.2					SBS.H...	11.3	1x
		1001-1200	M.750-1	9.2					SBS.H...	11.3	1x
		1201-1550	MK.500-1	9.1	M.500-1	9.2			SBS.H...	11.3	2x
		1551-1720	MK.750-1	9.1	V.AK.450-1	9.5			SBS.H...	11.3	2x
		1721-1970	MK.500-1	9.1	MK.500-1	9.1	V.AK.450-1	9.5	SBS.H...	11.3	3x
		1971-2220	MK.750-1	9.1	MK.500-1	9.1	V.AK.450-1	9.5	SBS.H...	11.3	3x
		2221-2470	MK.750-1	9.1	MK.750-1	9.1	V.AK.450-1	9.5	SBS.H...	11.3	3x
2471-2500	MK.750-1	9.1	MK.500-1	9.1	MK.500-1	9.1	SBS.H...	11.3	4x		
		V.AK.450-1	9.5								
	631-1475	421-2500	FL.IF-N...	6.1	EL.H.IF-N...	6.5					
	631-850	421-2500	V.AK.450-1	9.5					SBS.H...	11.3	1x
	851-1100		V.AK.450-1	9.5	MK.250-1	9.1			SBS.H...	11.3	2x
	1101-1360		V.AK.450-1	9.5	MK.500-1	9.1			SBS.H...	11.3	2x
	1361-1475		V.AK.450-1	9.5	MK.750-1	9.1			SBS.H...	11.3	2x
	631-800	421-1075	E11	4.5					SBS.H...	11.3	1x
	631-1475	1076-2500	E1	4.1					SBK.H...	11.2	1x
	801-1475	421-1075	E1	4.1					SBK.H...	11.2	1x

i marks a line with items that are always used, regardless of size

Turn-tilt fitting – central handle position

Suitable for burglary-resistant windows RC2 / RC2 N

- from 24 mm frame rebate depth - 13 mm groove centre position

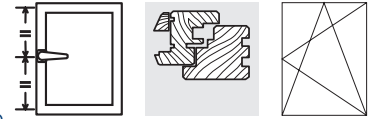

2

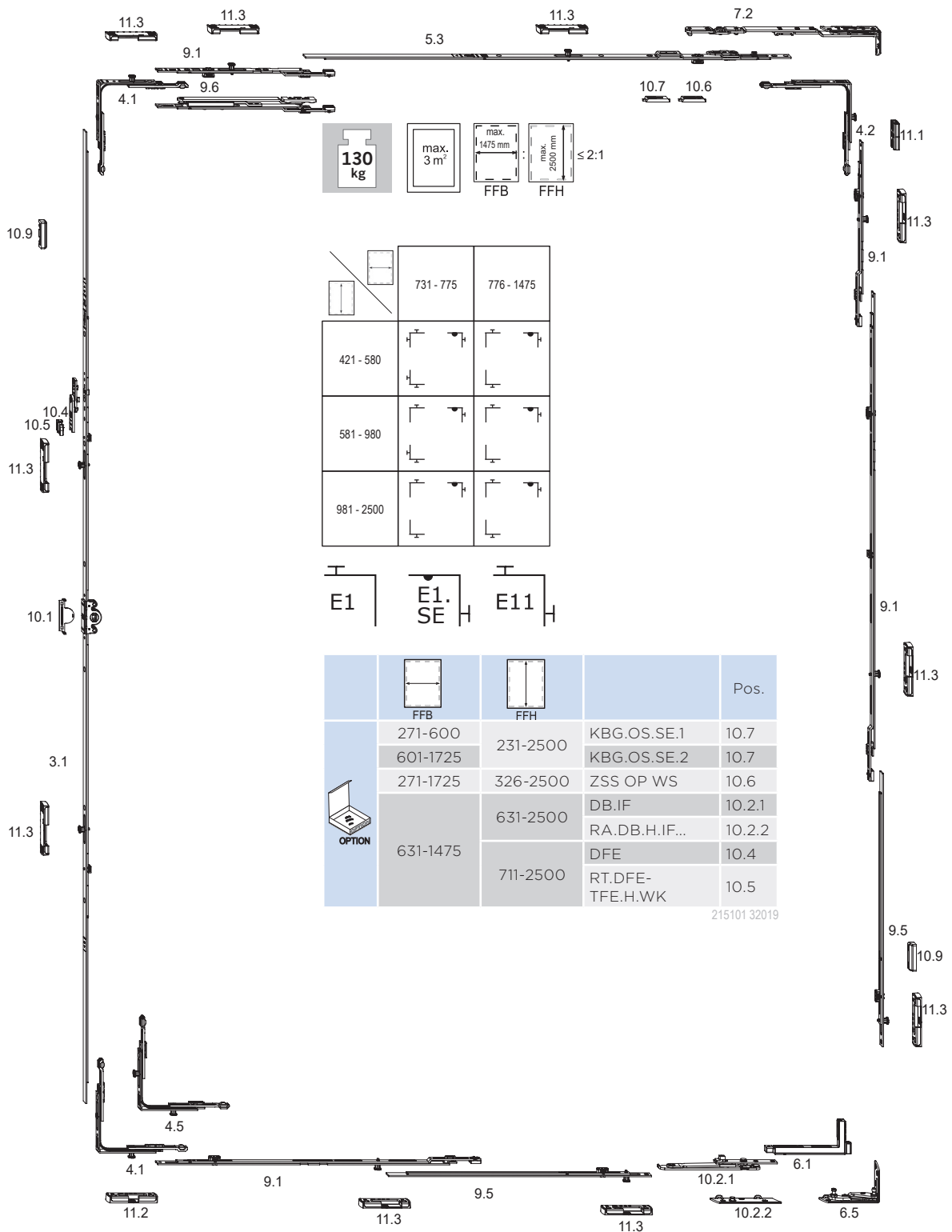

The shown distance between locking points is 1000 mm.

The locking distance to be used is the responsibility of the window manufacturer.

Turn-tilt fitting – central handle position

Suitable for burglary-resistant windows RC2 / RC2 N

- from 24 mm frame rebate depth - 13 mm groove centre position

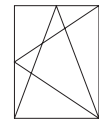
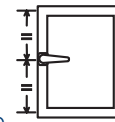

				Pos.		Pos.		Pos.		Pos.	
	i 631-1475	631-2500	AB.G.D.15,5	10.1	AL D...	10.9					
	631-1420	631-710	GAK.830-1	3.1			GK = 260		SBS.H...	11.3	1x
	631-1475	711-980	GAM.1050-1	3.1					SBS.H...	11.3	2x
		981-1400	GAM.1400-2	3.1					SBS.H...	11.3	2x
		1401-1800	GAM.1800-2	3.1					SBS.H...	11.3	2x
		1801-2300	GAM.2300-3	3.1					SBS.H...	11.3	3x
		2301-2500	GAM.1800-2	3.1	MK.500-1	9.1	MK.500-1	9.1	SBS.H...	11.3	4x
	631-1475	631-2500	E1	4.1					SBS.H...	11.3	1x
	631-730	631-2500	OS.SE.550	5.3	MK.150-1	9.8			SBS.H...	11.3	1x
	731-775		OS.SE.550	5.3	MK.250-1	9.1			SBS.H...	11.3	1x
	776-1025		OS.SE.1025-1	5.3					SBS.H...	11.3	1x
	1026-1275		OS.SE.1025-1	5.3	MK.250-1	9.1			SBS.H...	11.3	2x
	1276-1475		OS.SE.1025-1	5.3	MK.250-1	9.1	ZSR SL	9.6	SBS.H...	11.3	2x
	631-1475	631-2500	E1.SE	4.2	SH.IF-N...	7.2			SBA.H...	11.1	1x
	i 631-1475	631-2500	AL D...	10.9							
	631-1270	631-635	M.250-1	9.2					SBS.H...	11.3	1x
	631-1475	636-1000	MK.250-1	9.1	M.250-1	9.2			SBS.H...	11.3	2x
		1001-1200	MK.250-1	9.1	M.500-1	9.2			SBS.H...	11.3	2x
		1201-1550	MK.250-1	9.1	M.750-1	9.2			SBS.H...	11.3	2x
		1551-1720	MK.250-1	9.1	MK.500-1	9.1	V.AK.450-1	9.5	SBS.H...	11.3	3x
		1721-1970	MK.250-1	9.1	MK.750-1	9.1	V.AK.450-1	9.5	SBS.H...	11.3	3x
		1971-2220	MK.250-1	9.1	MK.500-1	9.1	MK.500-1	9.1	SBS.H...	11.3	4x
			V.AK.450-1	9.5							
		2221-2470	MK.250-1	9.1	MK.500-1	9.1	MK.750-1	9.1	SBS.H...	11.3	4x
2471-2500	MK.250-1	9.1	MK.500-1	9.1	MK.500-1	9.1	SBS.H...	11.3	5x		
		MK.500-1	9.1	V.AK.450-1	9.5						
	631-1475	631-2500	FL.IF-N...	6.1	EL.H.IF-N...	6.5					
	631-850	631-2500	V.AK.450-1	9.5					SBS.H...	11.3	1x
	851-1100		V.AK.450-1	9.5	MK.250-1	9.1			SBS.H...	11.3	2x
	1101-1360		V.AK.450-1	9.5	MK.500-1	9.1			SBS.H...	11.3	2x
	1361-1475		V.AK.450-1	9.5	MK.750-1	9.1			SBS.H...	11.3	2x
	631-775	631-980	E11	4.5					SBS.H...	11.3	1x
	631-1475	981-2500	E1	4.1					SBK.H...	11.2	1x
	776-1475	631-980	E1	4.1					SBK.H...	11.2	1x

i marks a line with items that are always used, regardless of size

2

Turn-tilt fitting – central handle position

Suitable for burglary-resistant windows RC2 / RC2 N
 - from 29 mm frame rebate depth - 13 mm groove centre position

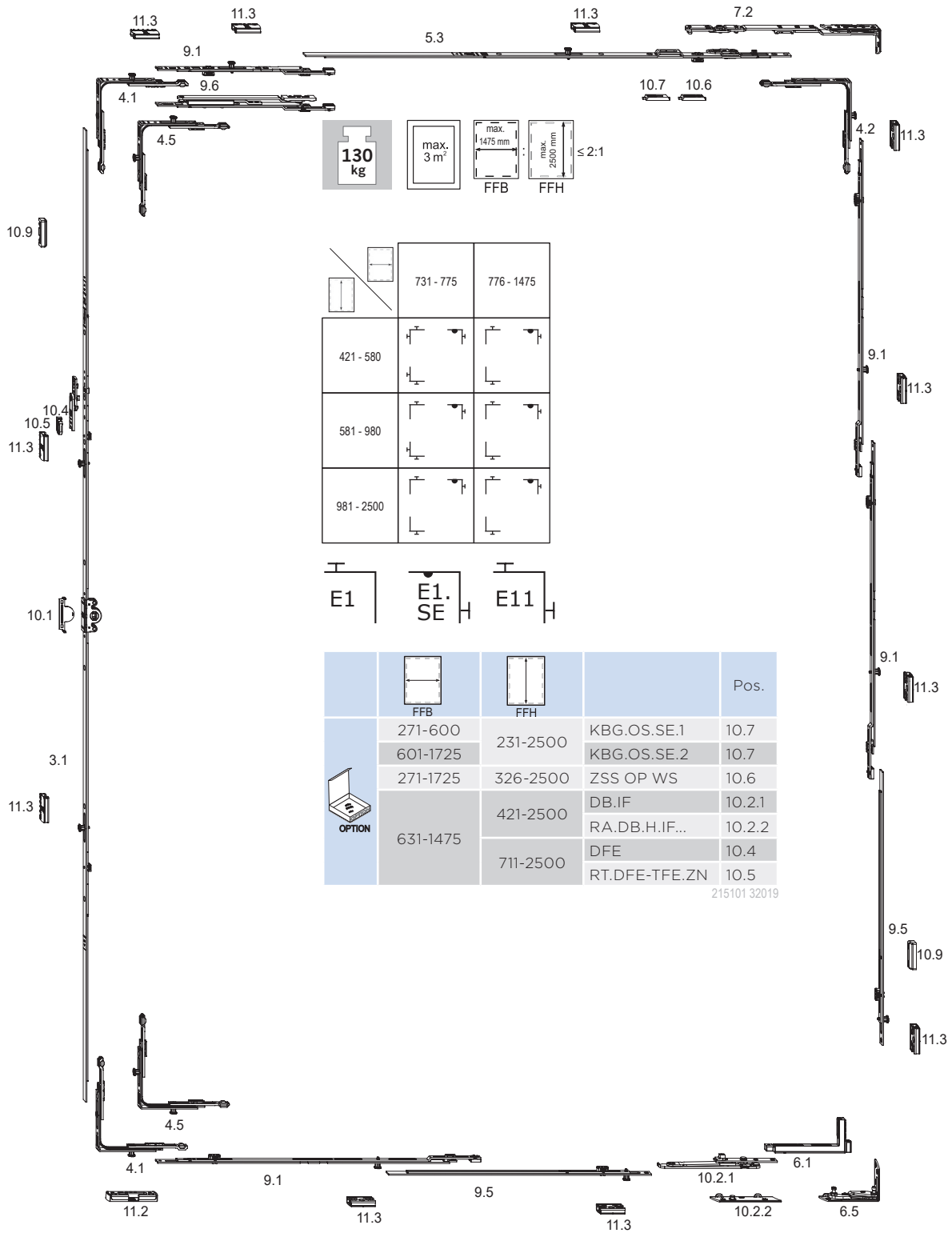

The shown distance between locking points is 1000 mm.

The locking distance to be used is the responsibility of the window manufacturer.



Turn-tilt fitting – central handle position

Suitable for burglary-resistant windows RC2 / RC2 N

- from 29 mm frame rebate depth - 13 mm groove centre

position



				Pos.		Pos.		Pos.		Pos.	
	i 631-1475	421-2500	AB.G.D.15,5	10.1	AL D...	10.9					
	631-920	421-460	GAK.465	3.1			GK = 210				
	631-1160	461-580	GAK.710	3.1			GK = 210				
	631-1420	581-710	GAK.830-1	3.1			GK = 260		SBS.H...	11.3	1x
	631-1475	711-980	GAM.1050-1	3.1					SBS.H...	11.3	2x
		981-1400	GAM.1400-2	3.1					SBS.H...	11.3	2x
		1401-1800	GAM.1800-2	3.1					SBS.H...	11.3	2x
		1801-2300	GAM.2300-3	3.1					SBS.H...	11.3	3x
	2301-2500	GAM.1800-2	3.1	MK.500-1	9.1	MK.500-1	9.1	SBS.H...	11.3	4x	
	631-775	421-580	E11	4.5					SBS.H...	11.3	2x
	631-1475	581-2500	E1	4.1					SBS.H...	11.3	1x
	776-1160	421-580	E1	4.1					SBS.H...	11.3	1x
	631-730	421-2500	OS.SE.550	5.3	MK.150-1	9.8			SBS.H...	11.3	1x
	731-775		OS.SE.550	5.3	MK.250-1	9.1			SBS.H...	11.3	1x
	776-1025		OS.SE.1025-1	5.3					SBS.H...	11.3	1x
	1026-1275		OS.SE.1025-1	5.3	MK.250-1	9.1			SBS.H...	11.3	2x
	1276-1475		OS.SE.1025-1	5.3	MK.250-1	9.1	ZSR SL	9.6	SBS.H...	11.3	2x
	631-1475	421-2500	E1.SE	4.2	SH.IF-N...	7.2			SBS.H...	11.3	1x
	i 631-1475	421-2500	AL D...	10.9							
	631-1170	421-585	M.250-1	9.2					SBS.H...	11.3	1x
	631-1475	586-1000	M.500-1	9.2					SBS.H...	11.3	1x
		1001-1200	M.750-1	9.2					SBS.H...	11.3	1x
		1201-1550	MK.500-1	9.1	M.500-1	9.2			SBS.H...	11.3	2x
		1551-1720	MK.750-1	9.1	V.AK.450-1	9.5			SBS.H...	11.3	2x
		1721-1970	MK.500-1	9.1	MK.500-1	9.1	V.AK.450-1	9.5	SBS.H...	11.3	3x
		1971-2220	MK.750-1	9.1	MK.500-1	9.1	V.AK.450-1	9.5	SBS.H...	11.3	3x
		2221-2470	MK.750-1	9.1	MK.750-1	9.1	V.AK.450-1	9.5	SBS.H...	11.3	3x
		2471-2500	MK.750-1	9.1	MK.500-1	9.1	MK.500-1	9.1	SBS.H...	11.3	4x
	V.AK.450-1	9.5									
	631-1475	421-2500	FL.IF-N...	6.1	EL.H.IF-N...	6.5					
	631-850	421-2500	V.AK.450-1	9.5					SBS.H...	11.3	1x
	851-1100		V.AK.450-1	9.5	MK.250-1	9.1			SBS.H...	11.3	2x
	1101-1360		V.AK.450-1	9.5	MK.500-1	9.1			SBS.H...	11.3	2x
	1361-1475		V.AK.450-1	9.5	MK.750-1	9.1			SBS.H...	11.3	2x
	631-775	421-980	E11	4.5					SBS.H...	11.3	1x
	631-1475	981-2500	E1	4.1					SBK.H...	11.2	1x
	776-1475	421-980	E1	4.1					SBK.H...	11.2	1x

i marks a line with items that are always used, regardless of size

Turn double sash fitting – constant handle position

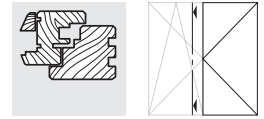

2

Basic equipment

9 mm and 13 mm groove centre position with circumferential locking points

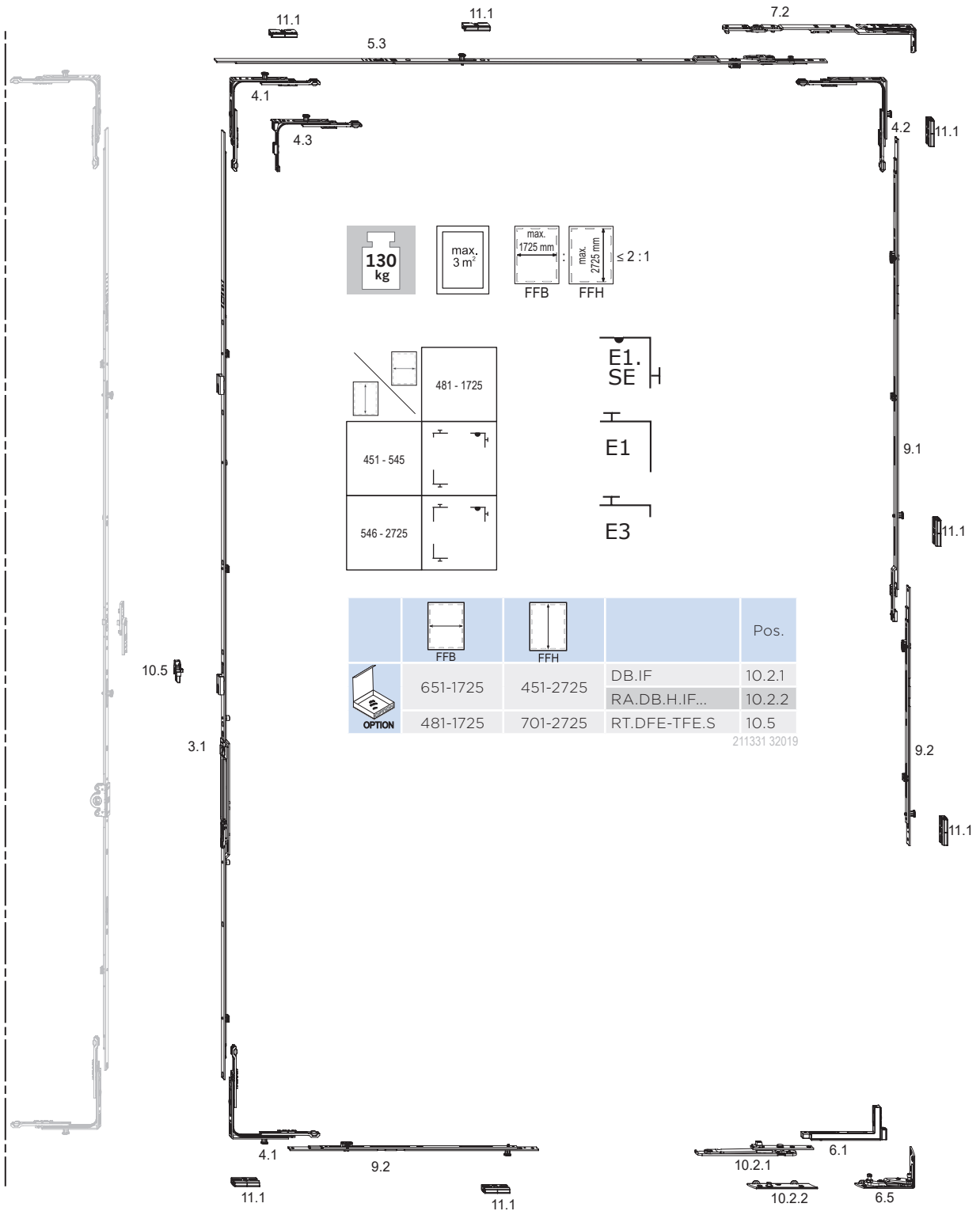

The shown distance between locking points is 1000 mm.









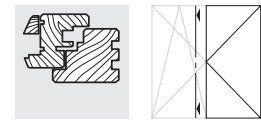

The locking distance to be used is the responsibility of the window manufacturer.

Turn double sash fitting - constant handle position

Basic equipment

9 mm and 13 mm groove centre position with circumferential locking points



				Pos.		Pos.		Pos.		Pos.		
	481-1400	451-700	GASK.710	3.1			GK = 210					
	481-1700	701-850	GASK.945-1	3.1			GK = 260					
	481-1725		851-1100	GASK.1100-1	3.1			GK = 375				
			1101-1325	GASK.1325-1	3.1			GK = 550				
			1326-1550	GASK.1550-1	3.1			GK = 550				
			1551-1775	GASK.1775-2	3.1			GK = 550				
			1776-2000	GASK.2000-2	3.1			GK = 1050				
			2001-2225	GASK.2225-2	3.1			GK = 1050				
			2226-2475	GASK.2225-2	3.1	MS.SO.250-1	9.3		GK = 1050			
2476-2725	GASK.2225-2	3.1	MS.SO.500-1	9.3		GK = 1050						
	481-1090	451-545	E3	4.3					SBA.H...	11.1	1x	
	481-1725	546-2725	E1	4.1					SBA.H...	11.1	1x	
	481-550	451-2725	OS.SE.550	5.3								
	551-800		OS.SE.800	5.3								
	801-1025		OS.SE.1025-1	5.3						SBA.H...	11.1	1x
	1026-1250		OS.SE.1250-1	5.3						SBA.H...	11.1	1x
	1251-1475		OS.SE.1250-1	5.3	MK.250-0	9.1				SBA.H...	11.1	1x
	1476-1500		OS.SE.1025-1	5.3	MK.250-0	9.1	MK.250-1	9.1		SBA.H...	11.1	2x
	1501-1725		OS.SE.1250-1	5.3	MK.250-0	9.1	MK.250-1	9.1		SBA.H...	11.1	2x
	481-1725	451-2725	E1.SE	4.2	SH.IF-N...	7.2			SBA.H...	11.1	1x	
	481-1725	1061-1485	M.500-1	9.2					SBA.H...	11.1	1x	
		1486-1735	M.750-1	9.2					SBA.H...	11.1	1x	
		1736-2235	MK.750-1	9.1	M.500-1	9.2			SBA.H...	11.1	2x	
		2236-2485	MK.750-1	9.1	M.750-1	9.2			SBA.H...	11.1	2x	
		2486-2725	MK.750-1	9.1	MK.750-1	9.1	M.500-1	9.2		SBA.H...	11.1	3x
	481-1725	451-2725	FL.IF-N...	6.1	EL.H.IF-N...	6.5						
	1041-1450	451-2725	M.500-1	9.2					SBA.H...	11.1	1x	
	1451-1725		M.750-1	9.2					SBA.H...	11.1	1x	
	481-1725	451-2725	E1	4.1					SBA.H...	11.1	1x	

 marks a line with items that are always used, regardless of size

Turn double-sash fitting - central handle position

Basic equipment

9 mm and 13 mm groove centre position with circumferential locking points

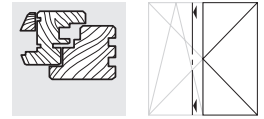

2

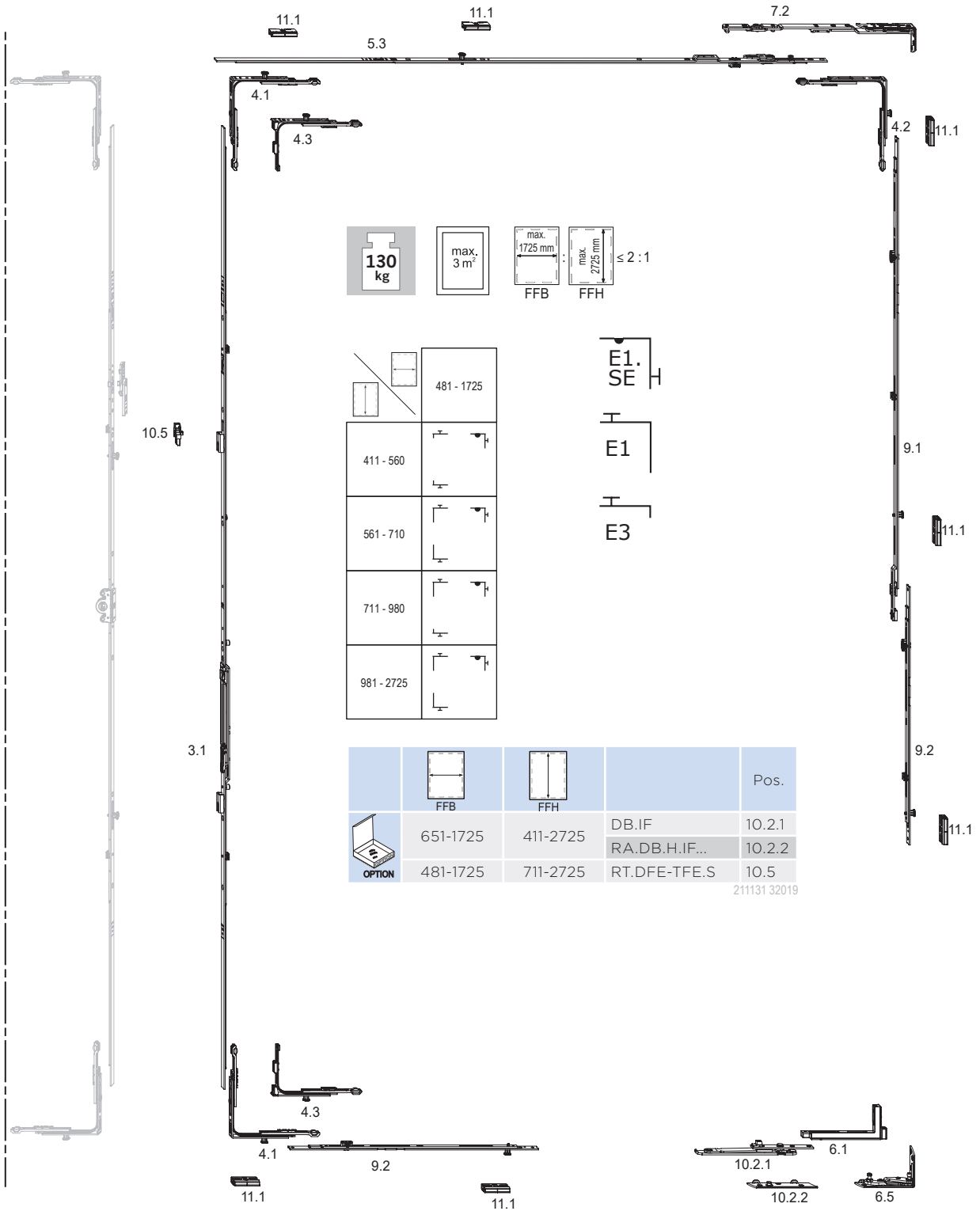

The shown distance between locking points is 1000 mm.
 The locking distance to be used is the responsibility of the window manufacturer.

Turn double-sash fitting – central handle position







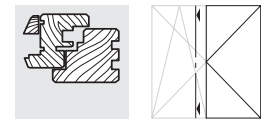



Basic equipment

9 mm and 13 mm groove centre position with circumferential locking

points



2

				Pos.		Pos.		Pos.		Pos.		
	481-1420	411-710	GASM.800	3.1								
	481-1725	711-980	GASM.1050-1.E3	3.1								
		981-1400	GASM.1400-1	3.1								
		1401-1800	GASM.1800-2	3.1								
		1801-2300	GASM.2300-3	3.1								
		2301-2725	GASM.2300-3	3.1	MS.SU.250-1	9.3	MS.SO.250-1	9.3				
	481-1120	411-560	E3	4.3					SBA.H...	11.1	1x	
	481-1725	561-2725	E1	4.1					SBA.H...	11.1	1x	
	481-550	411-2725	OS.SE.550	5.3								
	551-800		OS.SE.800	5.3								
	801-1025		OS.SE.1025-1	5.3						SBA.H...	11.1	1x
	1026-1250		OS.SE.1250-1	5.3						SBA.H...	11.1	1x
	1251-1475		OS.SE.1250-1	5.3	MK.250-0	9.1				SBA.H...	11.1	1x
	1476-1500		OS.SE.1025-1	5.3	MK.250-0	9.1	MK.250-1	9.1		SBA.H...	11.1	2x
	1501-1725		OS.SE.1250-1	5.3	MK.250-0	9.1	MK.250-1	9.1		SBA.H...	11.1	2x
	481-1725	411-2725	E1.SE	4.2	SH.IF-N...	7.2			SBA.H...	11.1	1x	
	481-1725	1061-1485	M.500-1	9.2					SBA.H...	11.1	1x	
		1486-1735	M.750-1	9.2					SBA.H...	11.1	1x	
		1736-2235	MK.750-1	9.1	M.500-1	9.2			SBA.H...	11.1	2x	
		2236-2485	MK.750-1	9.1	M.750-1	9.2			SBA.H...	11.1	2x	
		2486-2725	MK.750-1	9.1	MK.750-1	9.1	M.500-1	9.2		SBA.H...	11.1	3x
	481-1725	411-2725	FL.IF-N...	6.1	EL.H.IF-N...	6.5						
	1041-1450	411-2725	M.500-1	9.2					SBA.H...	11.1	1x	
	1451-1725		M.750-1	9.2					SBA.H...	11.1	1x	
	481-1120	411-560	E3	4.3					SBA.H...	11.1	1x	
	481-1420	561-710	E1	4.1					SBA.H...	11.1	1x	
	481-1725	711-980	E3	4.3					SBA.H...	11.1	1x	
		981-2725	E1	4.1					SBA.H...	11.1	1x	

 marks a line with items that are always used, regardless of size

Turn double sash fitting – constant handle position

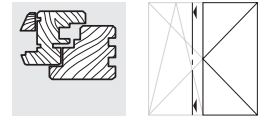

2

Basic equipment with claw bolt
9 mm and 13 mm groove centre position

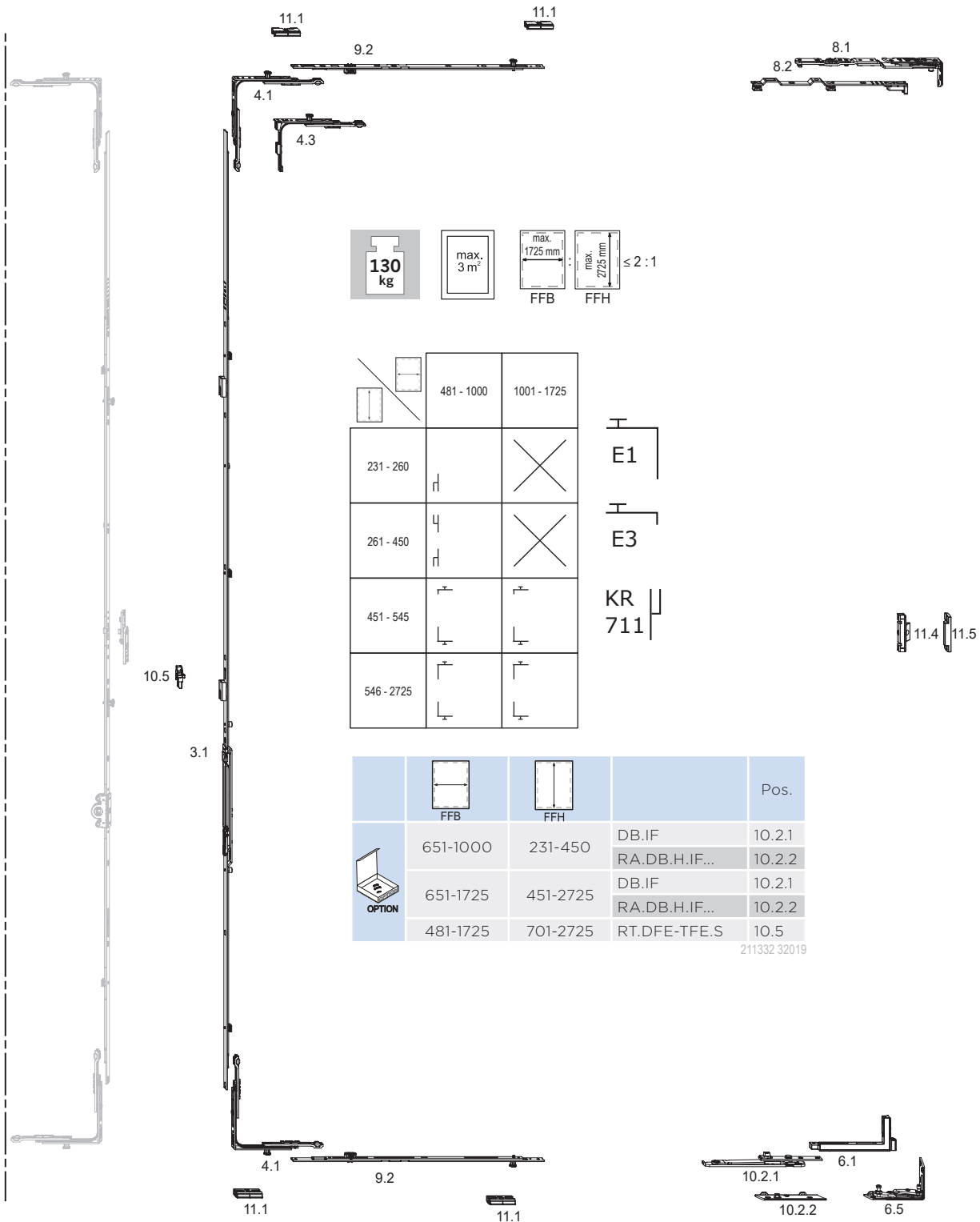









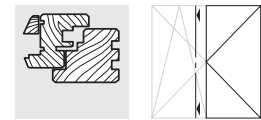

The shown distance between locking points is 1000 mm.
The locking distance to be used is the responsibility of the window manufacturer.

Turn double sash fitting – constant handle position

Basic equipment with claw bolt

9 mm and 13 mm groove centre position



				Pos.		Pos.		Pos.		Pos.		
	481-1400	451-700	GASK.710	3.1			GK = 210					
	481-1700	701-850	GASK.945-1	3.1			GK = 260					
	481-1725	851-1100		GASK.1100-1	3.1			GK = 375				
		1101-1325		GASK.1325-1	3.1			GK = 550				
		1326-1550		GASK.1550-1	3.1			GK = 550				
		1551-1775		GASK.1775-2	3.1			GK = 550				
		1776-2000		GASK.2000-2	3.1			GK = 1050				
		2001-2225		GASK.2225-2	3.1			GK = 1050				
		2226-2475		GASK.2225-2	3.1	MS.SO.250-1	9.3	GK = 1050				
2476-2725		GASK.2225-2	3.1	MS.SO.500-1	9.3	GK = 1050						
	481-900	261-450	KR F 711.C...	10.10								
	481-1090	451-545	E3	4.3				SBA.H...	11.1	1x		
	481-1725	546-2725	E1	4.1				SBA.H...	11.1	1x		
	1041-1450	451-2725	M.500-1	9.2				SBA.H...	11.1	1x		
	1451-1725		M.750-1	9.2				SBA.H...	11.1	1x		
 ⁱ	481-1725	231-2725	DL.H.IF-N...	8.1	DLS.IF...	8.2						
	481-1725	1001-2000	ZV-FT SL	11.4				ZV-RT.H...	11.5	1x		
		2001-2725	ZV-FT SL	11.4	ZV-FT SL	11.4		ZV-RT.H...	11.5	2x		
	481-900	231-450	FL.IF-N...	6.1	EL.H.IF-N...	6.5						
	481-1725	451-2725	FL.IF-N...	6.1	EL.H.IF-N...	6.5						
	1041-1450	451-2725	M.500-1	9.2				SBA.H...	11.1	1x		
	1451-1725		M.750-1	9.2				SBA.H...	11.1	1x		
	481-900	231-450	KR F 711.C...	10.10								
	481-1725	451-2725	E1	4.1				SBA.H...	11.1	1x		

ⁱ marks a line with items that are always used, regardless of size

Turn double-sash fitting - central handle position

Basic equipment with claw bolt

9 mm and 13 mm groove centre position

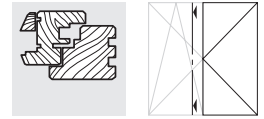

2

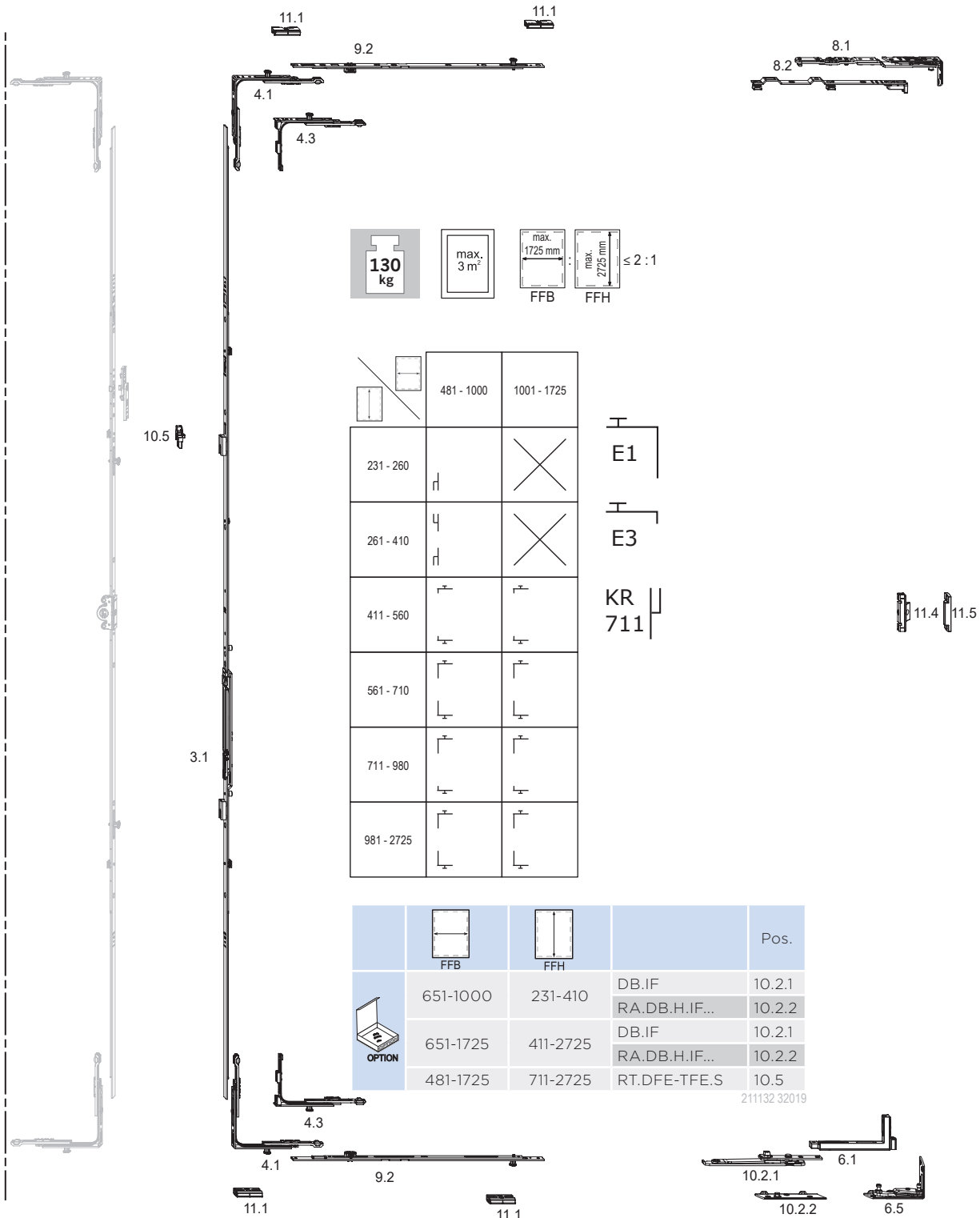

The shown distance between locking points is 1000 mm.

The locking distance to be used is the responsibility of the window manufacturer.







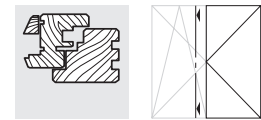



Turn double-sash fitting – central handle position

Basic equipment with claw bolt

9 mm and 13 mm groove centre position



2

				Pos.		Pos.		Pos.		Pos.	
	481-1420	411-710	GASM.800	3.1							
	481-1725	711-980	GASM.1050-1.E3	3.1							
		981-1400	GASM.1400-1	3.1							
		1401-1800	GASM.1800-2	3.1							
		1801-2300	GASM.2300-3	3.1							
		2301-2725	GASM.2300-3	3.1	MS.SU.250-1	9.3	MS.SO.250-1	9.3			
	481-820	261-410	KR F 711.C...	10.10							
	481-1120	411-560	E3	4.3				SBA.H...	11.1	1x	
	481-1725	561-2725	E1	4.1				SBA.H...	11.1	1x	
	1041-1450	411-2725	M.500-1	9.2				SBA.H...	11.1	1x	
	1451-1725		M.750-1	9.2				SBA.H...	11.1	1x	
	ⁱ 481-1725	231-2725	DL.H.IF-N...	8.1	DLS.IF...	8.2					
	481-1725	1001-2000	ZV-FT SL	11.4				ZV-RT.H...	11.5	1x	
		2001-2725	ZV-FT SL	11.4	ZV-FT SL	11.4		ZV-RT.H...	11.5	2x	
	481-820	231-410	FL.IF-N...	6.1	EL.H.IF-N...	6.5					
	481-1725	411-2725	FL.IF-N...	6.1	EL.H.IF-N...	6.5					
	1041-1450	411-2725	M.500-1	9.2				SBA.H...	11.1	1x	
	1451-1725		M.750-1	9.2				SBA.H...	11.1	1x	
	481-820	231-410	KR F 711.C...	10.10							
	481-1120	411-560	E3	4.3				SBA.H...	11.1	1x	
	481-1420	561-710	E1	4.1				SBA.H...	11.1	1x	
	481-1725	711-980	E3	4.3				SBA.H...	11.1	1x	
		981-2725	E1	4.1				SBA.H...	11.1	1x	

ⁱ marks a line with items that are always used, regardless of size

Turn double sash fitting – constant handle position

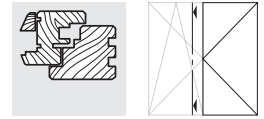

2 Suitable for burglary-resistant windows RC2 / RC2 N
 - from 24 mm frame rebate depth - 13 mm groove centre position

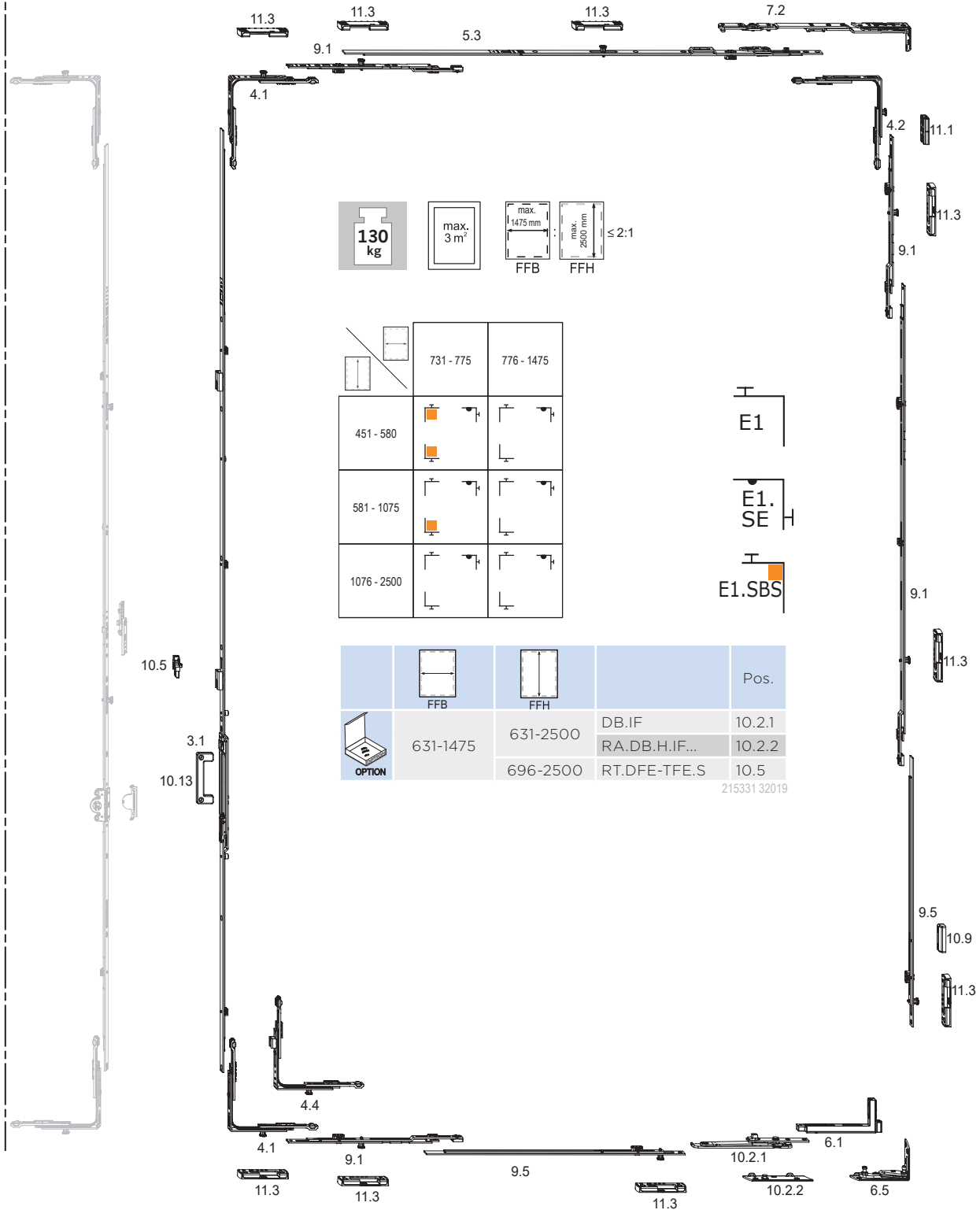









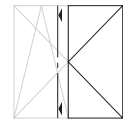



The shown distance between locking points is 1000 mm.
 The locking distance to be used is the responsibility of the window manufacturer.

Turn double sash fitting - constant handle position

Suitable for burglary-resistant windows RC2 / RC2 N

- from 24 mm frame rebate depth - 13 mm groove centre position



				Pos.		Pos.		Pos.		Pos.	
	 631-1475	631-2500	SNH.AGR	10.13							
	631-1390	631-695	GASK.830-1	3.1							
	631-1475	696-850	GASK.945-1	3.1							
		851-1075	GASK.1100-1	3.1							
		1076-1325	GASK.1325-2	3.1							
		1326-1525	GASK.1550-2	3.1							
		1526-1775	GASK.1775-2	3.1							
		1776-2000	GASK.2000-2	3.1							
		2001-2225	GASK.2225-2	3.1							
		2226-2475	GASK.2225-2	3.1	MS.SO.250-1	9.3					
2476-2500	GASK.2225-2	3.1	MS.SO.500-1	9.3							
	631-1475	631-2500	E1	4.1					SBS.H...	11.3	1x
	631-730	631-2500	OS.SE.550	5.3	MK.150-1	9.8			SBS.H...	11.3	1x
	731-775		OS.SE.550	5.3	MK.250-1	9.1			SBS.H...	11.3	1x
	776-1025		OS.SE.1025-1	5.3					SBS.H...	11.3	1x
	1026-1275		OS.SE.1025-1	5.3	MK.250-1	9.1			SBS.H...	11.3	2x
	1276-1475		OS.SE.1025-1	5.3	MK.250-0	9.1	MK.250-1	9.1	SBS.H...	11.3	2x
	631-1475	631-2500	E1.SE	4.2	SH.IF-N...	7.2			SBA.H...	11.1	1x
	 631-1475	631-2500	AL D...	10.9							
	631-1270	631-635	M.250-1	9.2					SBS.H...	11.3	1x
	631-1475	636-1000	MK.250-1	9.1	M.250-1	9.2			SBS.H...	11.3	2x
		1001-1200	MK.250-1	9.1	M.500-1	9.2			SBS.H...	11.3	2x
		1201-1550	MK.250-1	9.1	M.750-1	9.2			SBS.H...	11.3	2x
		1551-1720	MK.250-1	9.1	MK.500-1	9.1	V.AK.450-1	9.5	SBS.H...	11.3	3x
		1721-1970	MK.250-1	9.1	MK.750-1	9.1	V.AK.450-1	9.5	SBS.H...	11.3	3x
		1971-2220	MK.250-1	9.1	MK.500-1	9.1	MK.500-1	9.1	SBS.H...	11.3	4x
		2221-2470	MK.250-1	9.1	MK.500-1	9.1	MK.750-1	9.1	SBS.H...	11.3	4x
			V.AK.450-1	9.5							
2471-2500	MK.250-1	9.1	MK.500-1	9.1	MK.500-1	9.1	SBS.H...	11.3	5x		
			MK.500-1	9.1	V.AK.450-1	9.5					
	631-1475	631-2500	FL.IF-N...	6.1	EL.H.IF-N...	6.5					
	631-850	631-2500	V.AK.450-1	9.5					SBS.H...	11.3	1x
	851-1100		V.AK.450-1	9.5	MK.250-1	9.1			SBS.H...	11.3	2x
	1101-1360		V.AK.450-1	9.5	MK.500-1	9.1			SBS.H...	11.3	2x
	1361-1475		V.AK.450-1	9.5	MK.750-1	9.1			SBS.H...	11.3	2x
	631-775	631-1075	E1.SBS.U	4.4					SBS.H...	11.3	1x
	631-1475	1076-2500	E1	4.1					SBS.H...	11.3	1x
	776-1475	631-1075	E1	4.1					SBS.H...	11.3	1x

 marks a line with items that are always used, regardless of size

Turn double sash fitting – constant handle position

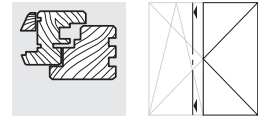

2 Suitable for burglary-resistant windows RC2 / RC2 N
 - from 29 mm frame rebate depth - 13 mm groove centre position

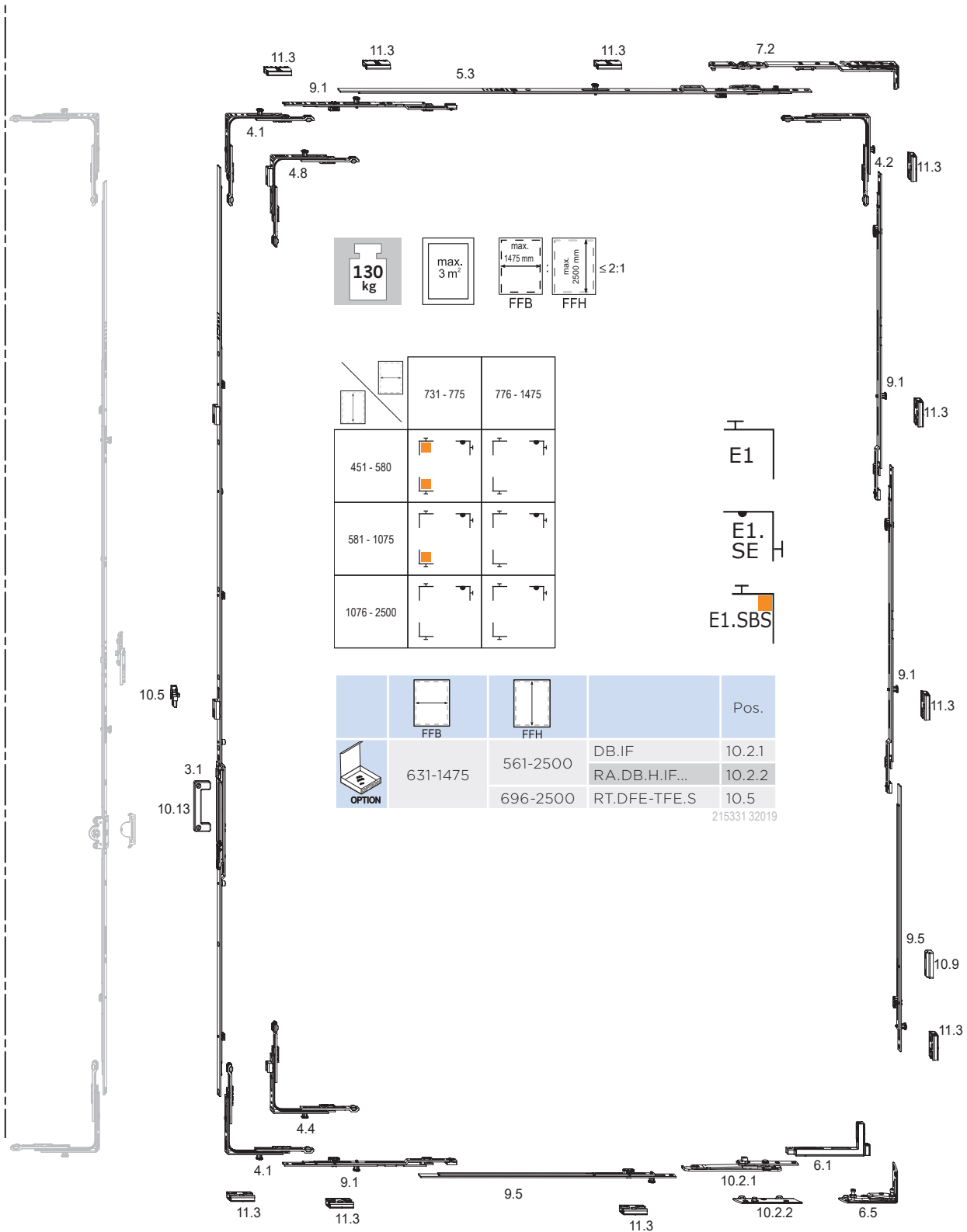

The shown distance between locking points is 1000 mm.









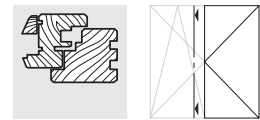

The locking distance to be used is the responsibility of the window manufacturer.

Turn double sash fitting - constant handle position

Suitable for burglary-resistant windows RC2 / RC2 N

- from 29 mm frame rebate depth - 13 mm groove centre position



				Pos.		Pos.		Pos.		Pos.		
	<i>i</i> 631-1475	561-2500	SNH.AGR	10.13								
	631-1160	561-580	GASK.710	3.1								
	631-1390	581-695	GASK.830-1	3.1								
	631-1475	696-850	GASK.945-1	3.1								
		851-1075	GASK.1100-1	3.1								
		1076-1325	GASK.1325-2	3.1								
		1326-1525	GASK.1550-2	3.1								
		1526-1775	GASK.1775-2	3.1								
		1776-2000	GASK.2000-2	3.1								
		2001-2225	GASK.2225-2	3.1								
2226-2475	GASK.2225-2	3.1	MS.SO.250-1	9.3								
2476-2500	GASK.2225-2	3.1	MS.SO.500-1	9.3								
	631-775	561-580	E1.SBS.O	4.8					SBS.H...	11.3	1x	
	631-1475	581-2500	E1	4.1					SBS.H...	11.3	1x	
	776-1160	561-580	E1	4.1					SBS.H...	11.3	1x	
	631-730	561-2500	OS.SE.550	5.3	MK.150-1	9.8			SBS.H...	11.3	1x	
	731-775		OS.SE.550	5.3	MK.250-1	9.1			SBS.H...	11.3	1x	
	776-1025		OS.SE.1025-1	5.3					SBS.H...	11.3	1x	
	1026-1275		OS.SE.1025-1	5.3	MK.250-1	9.1			SBS.H...	11.3	2x	
	1276-1475		OS.SE.1025-1	5.3	MK.250-0	9.1	MK.250-1	9.1	SBS.H...	11.3	2x	
	631-1475	561-2500	E1.SE	4.2	SH.IF-N...	7.2			SBS.H...	11.3	1x	
	<i>i</i> 631-1475	561-2500	AL D...	10.9								
	631-1170	561-585	M.250-1	9.2					SBS.H...	11.3	1x	
	631-1475	586-1000	M.500-1	9.2						SBS.H...	11.3	1x
		1001-1200	M.750-1	9.2						SBS.H...	11.3	1x
		1201-1550	MK.500-1	9.1	M.500-1	9.2				SBS.H...	11.3	2x
		1551-1720	MK.750-1	9.1	V.AK.450-1	9.5				SBS.H...	11.3	2x
		1721-1970	MK.500-1	9.1	MK.500-1	9.1	V.AK.450-1	9.5	SBS.H...	11.3	3x	
		1971-2220	MK.750-1	9.1	MK.500-1	9.1	V.AK.450-1	9.5	SBS.H...	11.3	3x	
		2221-2470	MK.750-1	9.1	MK.750-1	9.1	V.AK.450-1	9.5	SBS.H...	11.3	3x	
2471-2500	MK.750-1	9.1	MK.500-1	9.1	MK.500-1	9.1	SBS.H...	11.3	4x			
	V.AK.450-1	9.5										
	631-1475	561-2500	FL.IF-N...	6.1	EL.H.IF-N...	6.5						
	631-850	561-2500	V.AK.450-1	9.5					SBS.H...	11.3	1x	
	851-1100		V.AK.450-1	9.5	MK.250-1	9.1			SBS.H...	11.3	2x	
	1101-1360		V.AK.450-1	9.5	MK.500-1	9.1			SBS.H...	11.3	2x	
	1361-1475		V.AK.450-1	9.5	MK.750-1	9.1			SBS.H...	11.3	2x	
	631-775	561-1075	E1.SBS.U	4.4					SBS.H...	11.3	1x	
	631-1475	1076-2500	E1	4.1					SBS.H...	11.3	1x	
	776-1475	561-1075	E1	4.1					SBS.H...	11.3	1x	

i marks a line with items that are always used, regardless of size

Turn double-sash fitting - central handle position

Suitable for burglary-resistant windows RC2 / RC2 N

- from 24 mm frame rebate depth - 13 mm groove centre position

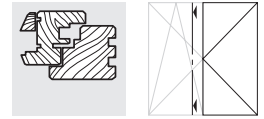

2



The shown distance between locking points is 1000 mm.









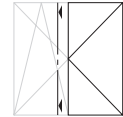

The locking distance to be used is the responsibility of the window manufacturer.

Turn double-sash fitting – central handle position

Suitable for burglary-resistant windows RC2 / RC2 N

- from 24 mm frame rebate depth - 13 mm groove centre position



				Pos.		Pos.		Pos.		Pos.	
	i 631-1475	631-2500	SNH.AGR	10.13							
	631-1420	631-710	GASK.830-1	3.1							
	851-1475	711-980	GASM.1050-1.E3	3.1							
	631-1475	981-1400	GASM.1400-2	3.1							
		1401-1800	GASM.1800-2	3.1							
1801-2300		GASM.2300-3	3.1								
	2301-2500	GASM.1800-2	3.1	MS.SU.500-1	9.3	MS.SO.500-1	9.3				
	631-1420	631-710	E1	4.1				SBS.H...	11.3	1x	
	631-1475	981-2500	E1	4.1				SBS.H...	11.3	1x	
	851-1475	711-980	E1	4.1				SBS.H...	11.3	1x	
	631-730	631-710	OS.SE.550	5.3	MK.150-1	9.8		SBS.H...	11.3	1x	
		981-2500	OS.SE.550	5.3	MK.150-1	9.8		SBS.H...	11.3	1x	
	731-775	631-710	OS.SE.550	5.3	MK.250-1	9.1		SBS.H...	11.3	1x	
		981-2500	OS.SE.550	5.3	MK.250-1	9.1		SBS.H...	11.3	1x	
	776-1025	631-710	OS.SE.1025-1	5.3				SBS.H...	11.3	1x	
		981-2500	OS.SE.1025-1	5.3				SBS.H...	11.3	1x	
	851-1025	711-980	OS.SE.1025-1	5.3				SBS.H...	11.3	1x	
	1026-1275	631-2500	OS.SE.1025-1	5.3	MK.250-1	9.1		SBS.H...	11.3	2x	
1276-1475		OS.SE.1025-1	5.3	MK.250-0	9.1	MK.250-1	9.1	SBS.H...	11.3	2x	
	631-1420	631-710	E1.SE	4.2	SH.IF-N...	7.2		SBA.H...	11.1	1x	
	631-1475	981-2500	E1.SE	4.2	SH.IF-N...	7.2		SBA.H...	11.1	1x	
	851-1475	711-980	E1.SE	4.2	SH.IF-N...	7.2		SBA.H...	11.1	1x	
	i 631-1475	631-2500	AL D...	10.9							
	631-1270	631-635	M.250-1	9.2				SBS.H...	11.3	1x	
	631-1420	636-710	MK.250-1	9.1	M.250-1	9.2		SBS.H...	11.3	2x	
	851-1475	711-980	MK.250-1	9.1	M.250-1	9.2		SBS.H...	11.3	2x	
	631-1475	981-1000	MK.250-1	9.1	M.250-1	9.2		SBS.H...	11.3	2x	
		1001-1200	MK.250-1	9.1	M.500-1	9.2		SBS.H...	11.3	2x	
		1201-1550	MK.250-1	9.1	M.750-1	9.2		SBS.H...	11.3	2x	
		1551-1720	MK.250-1	9.1	MK.500-1	9.1	V.AK.450-1	9.5	SBS.H...	11.3	3x
		1721-1970	MK.250-1	9.1	MK.750-1	9.1	V.AK.450-1	9.5	SBS.H...	11.3	3x
		1971-2220	MK.250-1	9.1	MK.500-1	9.1	MK.500-1	9.1	SBS.H...	11.3	4x
			V.AK.450-1	9.5							
		2221-2470	MK.250-1	9.1	MK.500-1	9.1	MK.750-1	9.1	SBS.H...	11.3	4x
V.AK.450-1	9.5										
2471-2500	MK.250-1	9.1	MK.500-1	9.1	MK.500-1	9.1	SBS.H...	11.3	5x		
	MK.500-1	9.1	V.AK.450-1	9.5							
	631-1420	631-710	FL.IF-N...	6.1	EL.H.IF-N...	6.5					
	851-1475	711-980	FL.IF-N...	6.1	EL.H.IF-N...	6.5					
	631-1475	981-2500	FL.IF-N...	6.1	EL.H.IF-N...	6.5					
	631-850	631-710	V.AK.450-1	9.5				SBS.H...	11.3	1x	
		981-2500	V.AK.450-1	9.5				SBS.H...	11.3	1x	
	851-1100		V.AK.450-1	9.5	MK.250-1	9.1		SBS.H...	11.3	2x	
	1101-1360	631-2500	V.AK.450-1	9.5	MK.500-1	9.1		SBS.H...	11.3	2x	
1361-1475		V.AK.450-1	9.5	MK.750-1	9.1		SBS.H...	11.3	2x		
	631-775	631-710	E1.SBS.U	4.4				SBS.H...	11.3	1x	
	631-1475	981-2500	E1	4.1				SBS.H...	11.3	1x	
	776-1420	631-710	E1	4.1				SBS.H...	11.3	1x	
	851-1475	711-980	E3	4.6				SBS.H...	11.3	1x	

i marks a line with items that are always used, regardless of size

Turn double-sash fitting - central handle position

Suitable for burglary-resistant windows RC2 / RC2 N

- from 29 mm frame rebate depth - 13 mm groove centre position

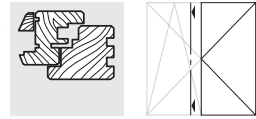

2



The shown distance between locking points is 1000 mm.









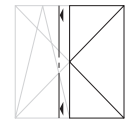



The locking distance to be used is the responsibility of the window manufacturer.

Turn double-sash fitting – central handle position

Suitable for burglary-resistant windows RC2 / RC2 N

- from 29 mm frame rebate depth - 13 mm groove centre position



				Pos.		Pos.		Pos.		Pos.	
	 631-1475	561-2500	SNH.AGR	10.13							
	631-1160	561-580	GASK.710	3.1							
	631-1420	581-710	GASK.830-1	3.1							
	851-1475	711-980	GASM.1050-1.E3	3.1							
	631-1475	981-1400	GASM.1400-2	3.1							
		1401-1800	GASM.1800-2	3.1							
		1801-2300	GASM.2300-3	3.1							
2301-2500		GASM.1800-2	3.1	MS.SU.500-1	9.3	MS.SO.500-1	9.3				
	631-775	561-580	E1.SBS.O	4.8				SBS.H...	11.3	1x	
	631-1420	581-710	E1	4.1				SBS.H...	11.3	1x	
	631-1475	981-2500	E1	4.1				SBS.H...	11.3	1x	
	776-1160	561-580	E1	4.1				SBS.H...	11.3	1x	
	851-1475	711-980	E1	4.1				SBS.H...	11.3	1x	
	631-730	561-710	OS.SE.550	5.3	MK.150-1	9.8		SBS.H...	11.3	1x	
		981-2500	OS.SE.550	5.3	MK.150-1	9.8		SBS.H...	11.3	1x	
	731-775	561-710	OS.SE.550	5.3	MK.250-1	9.1		SBS.H...	11.3	1x	
		981-2500	OS.SE.550	5.3	MK.250-1	9.1		SBS.H...	11.3	1x	
	776-1025	561-710	OS.SE.1025-1	5.3				SBS.H...	11.3	1x	
		981-2500	OS.SE.1025-1	5.3				SBS.H...	11.3	1x	
	851-1025	711-980	OS.SE.1025-1	5.3				SBS.H...	11.3	1x	
	1026-1275	561-2500	OS.SE.1025-1	5.3	MK.250-1	9.1		SBS.H...	11.3	2x	
1276-1475	OS.SE.1025-1		5.3	MK.250-0	9.1	MK.250-1	9.1	SBS.H...	11.3	2x	
	631-1420	561-710	E1.SE	4.2	SH.IF-N...	7.2		SBS.H...	11.3	1x	
	631-1475	981-2500	E1.SE	4.2	SH.IF-N...	7.2		SBS.H...	11.3	1x	
	851-1475	711-980	E1.SE	4.2	SH.IF-N...	7.2		SBS.H...	11.3	1x	
	 631-1475	561-2500	AL D...	10.9							
	631-1170	561-585	M.250-1	9.2				SBS.H...	11.3	1x	
	631-1420	586-710	M.500-1	9.2				SBS.H...	11.3	1x	
	851-1475	711-980	M.500-1	9.2				SBS.H...	11.3	1x	
	631-1475	981-1000	M.500-1	9.2				SBS.H...	11.3	1x	
		1001-1200	M.750-1	9.2				SBS.H...	11.3	1x	
		1201-1550	MK.500-1	9.1	M.500-1	9.2		SBS.H...	11.3	2x	
		1551-1720	MK.750-1	9.1	V.AK.450-1	9.5		SBS.H...	11.3	2x	
		1721-1970	MK.500-1	9.1	MK.500-1	9.1	V.AK.450-1	9.5	SBS.H...	11.3	3x
		1971-2220	MK.750-1	9.1	MK.500-1	9.1	V.AK.450-1	9.5	SBS.H...	11.3	3x
		2221-2470	MK.750-1	9.1	MK.750-1	9.1	V.AK.450-1	9.5	SBS.H...	11.3	3x
2471-2500		MK.750-1	9.1	MK.500-1	9.1	MK.500-1	9.1	SBS.H...	11.3	4x	
		V.AK.450-1	9.5								
	631-1420	561-710	FL.IF-N...	6.1	EL.H.IF-N...	6.5					
	851-1475	711-980	FL.IF-N...	6.1	EL.H.IF-N...	6.5					
	631-1475	981-2500	FL.IF-N...	6.1	EL.H.IF-N...	6.5					
	631-850	561-710	V.AK.450-1	9.5				SBS.H...	11.3	1x	
		981-2500	V.AK.450-1	9.5				SBS.H...	11.3	1x	
	851-1100		V.AK.450-1	9.5	MK.250-1	9.1		SBS.H...	11.3	2x	
	1101-1360	561-2500	V.AK.450-1	9.5	MK.500-1	9.1		SBS.H...	11.3	2x	
	1361-1475		V.AK.450-1	9.5	MK.750-1	9.1		SBS.H...	11.3	2x	
	631-775	561-710	E1.SBS.U	4.4				SBS.H...	11.3	1x	
	631-1475	981-2500	E1	4.1				SBS.H...	11.3	1x	
	776-1420	561-710	E1	4.1				SBS.H...	11.3	1x	
	851-1475	711-980	E3	4.6				SBS.H...	11.3	1x	

 marks a line with items that are always used, regardless of size

Turn-tilt fitting – constant handle position

Basic equipment – Tilt before turn

9 mm and 13 mm groove centre position

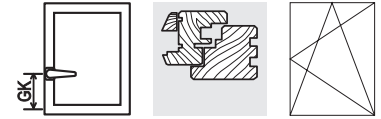

2

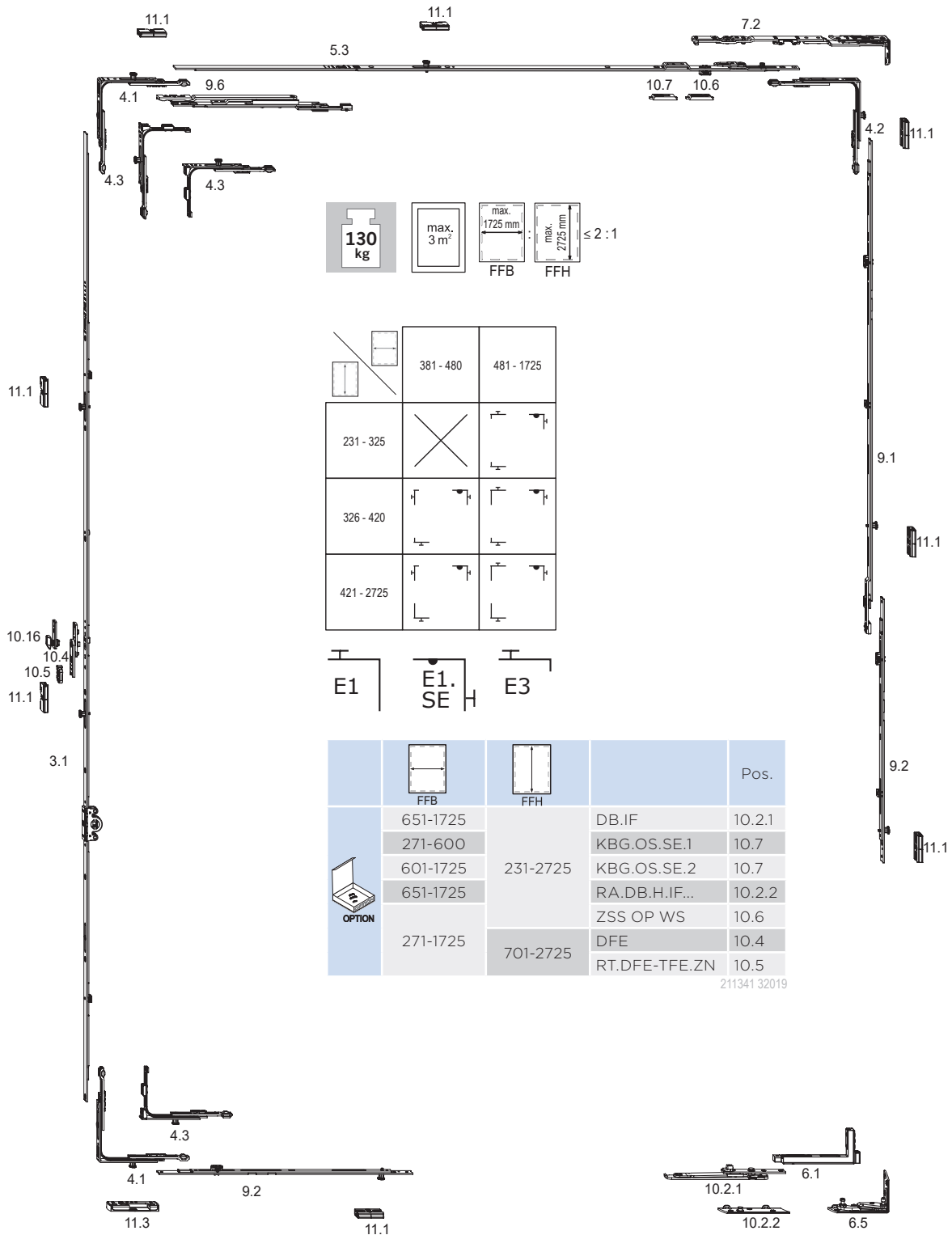

The shown distance between locking points is 1000 mm.









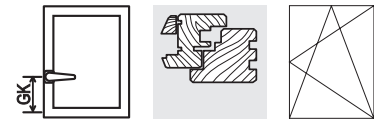

The locking distance to be used is the responsibility of the window manufacturer.

Turn-tilt fitting – constant handle position

Basic equipment – Tilt before turn

9 mm and 13 mm groove centre position



				Pos.		Pos.		Pos.		Pos.	
	481-650	231-325	GAK.465	3.1			GK = 114				
	381-840	326-420	GAK.465	3.1			GK = 114				
	381-920	421-460	GAK.465	3.1			GK = 210				
	381-1400	461-700	GAK.710	3.1			GK = 210				
	381-1700	701-850	GAK.945-1	3.1	FSF	10.16	GK = 260		SBA.H...	11.1	1x
	381-1725	851-1100	GAK.1100-1	3.1	FSF	10.16	GK = 375		SBA.H...	11.1	1x
		1101-1325	GAK.1325-1	3.1	FSF	10.16	GK = 550		SBA.H...	11.1	1x
		1326-1550	GAK.1550-1	3.1	FSF	10.16	GK = 550		SBA.H...	11.1	1x
		1551-1775	GAK.1775-2	3.1	FSF	10.16	GK = 550		SBA.H...	11.1	2x
		1776-2000	GAK.2000-2	3.1	FSF	10.16	GK = 1050		SBA.H...	11.1	2x
2001-2225		GAK.2225-2	3.1	FSF	10.16	GK = 1050		SBA.H...	11.1	2x	
2226-2475		GAK.2225-2 MK.250-1	3.1 9.1	FSF	10.16	GK = 1050		SBA.H...	11.1	3x	
2476-2725	GAK.2225-2 MK.500-1	3.1 9.1	FSF	10.16	GK = 1050		SBA.H...	11.1	3x		
	381-480	326-2725	E3	4.3					SBA.H...	11.1	1x
	481-650	231-325	E3	4.3					SBA.H...	11.1	1x
	481-1725	326-2725	E1	4.1					SBA.H...	11.1	1x
	381-550	326-2725	OS.SE.550.E	5.3							
	481-550	231-325	OS.SE.550.E	5.3							
	551-800	231-2725	OS.SE.800.E	5.3							
	801-1025		OS.SE.1025-1.E	5.3					SBA.H...	11.1	1x
	1026-1250		OS.SE.1250-1.E	5.3					SBA.H...	11.1	1x
	1251-1475		OS.SE.1250-1.E	5.3	MK.250-0	9.1			SBA.H...	11.1	1x
	1476-1500		OS.SE.1025-1.E	5.3	MK.250-1	9.1	ZSRE SL	9.6	SBA.H...	11.1	2x
1501-1725	OS.SE.1250-1.E	5.3	MK.250-1	9.1	ZSRE SL	9.6	SBA.H...	11.1	2x		
	381-1725	326-2725	E1.SE	4.2	SH.IF-N.E...	7.2			SBA.H...	11.1	1x
	481-650	231-325	E1.SE	4.2	SH.IF-N.E...	7.2			SBA.H...	11.1	1x
	381-1725	1061-1485	M.500-1	9.2					SBA.H...	11.1	1x
		1486-1735	M.750-1	9.2					SBA.H...	11.1	1x
		1736-2235	MK.750-1	9.1	M.500-1	9.2			SBA.H...	11.1	2x
		2236-2485	MK.750-1	9.1	M.750-1	9.2			SBA.H...	11.1	2x
		2486-2725	MK.750-1	9.1	MK.750-1	9.1	M.500-1	9.2	SBA.H...	11.1	3x
	481-650	231-325	FL.IF-N...	6.1	EL.H.IF-N...	6.5					
	381-1725	326-2725	FL.IF-N...	6.1	EL.H.IF-N...	6.5					
	1041-1450	231-2725	M.500-1	9.2					SBA.H...	11.1	1x
	1451-1725		M.750-1	9.2					SBA.H...	11.1	1x
	381-840	326-420	E3	4.3					SBS.H...	11.3	1x
	381-1725	421-2725	E1	4.1					SBS.H...	11.3	1x
	481-650	231-325	E3	4.3					SBS.H...	11.3	1x

In case of sash rebate heights (FFH) of < 701 mm it is not possible to install a fail-safe device directly onto the drive rod. By combining a shorter drive rod with an MK.250.FSF interlocking rod, the required fail-safe device can be integrated from a sash rebate height of > 475 mm.

 marks a line with items that are always used, regardless of size

Turn-tilt fitting – central handle position

Basic equipment – Tilt before turn

9 mm and 13 mm groove centre position

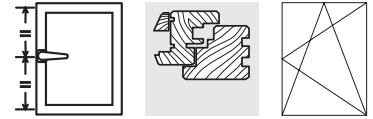

2

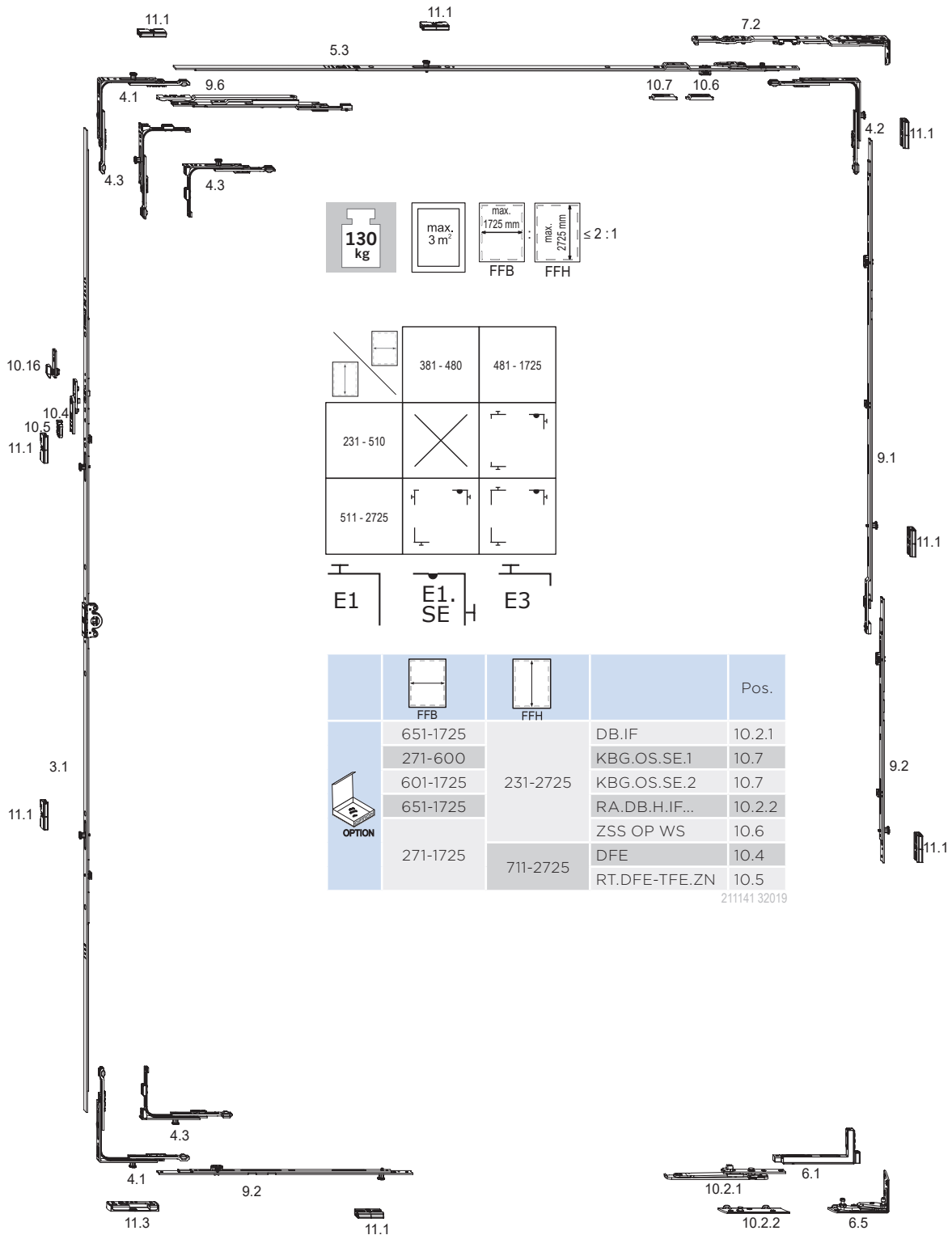

The shown distance between locking points is 1000 mm.







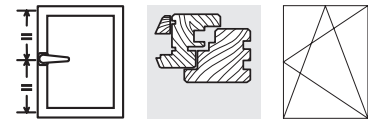

The locking distance to be used is the responsibility of the window manufacturer.

Turn-tilt fitting – central handle position

Basic equipment – Tilt before turn

9 mm and 13 mm groove centre position



				Pos.		Pos.		Pos.		Pos.		
	481-650	231-325	GAK.465	3.1			GK = 114					
	481-1020	326-510	GAM.800	3.1								
	381-1420	511-710	GAM.800	3.1								
	381-1725	711-980	GAM.1050	3.1	FSF	10.16						
		981-1400	GAM.1400-1	3.1	FSF	10.16			SBA.H...	11.1	1x	
		1401-1800	GAM.1800-2	3.1	FSF	10.16			SBA.H...	11.1	2x	
		1801-2300	GAM.2300-3	3.1	FSF	10.16			SBA.H...	11.1	3x	
2301-2725	GAM.2300-3	3.1	FSF	10.16	MK.250-1	9.1	SBA.H...	11.1	5x			
2301-2725	MK.250-1	9.1										
	381-480	511-2725	E3	4.3					SBA.H...	11.1	1x	
	481-1020	231-510	E3	4.3					SBA.H...	11.1	1x	
	481-1725	511-2725	E1	4.1					SBA.H...	11.1	1x	
	381-550	511-2725	OS.SE.550.E	5.3								
	481-550	231-510	OS.SE.550.E	5.3								
	551-800	231-2725	OS.SE.800.E	5.3								
	801-1025		OS.SE.1025-1.E	5.3					SBA.H...	11.1	1x	
	1026-1250		OS.SE.1250-1.E	5.3					SBA.H...	11.1	1x	
	1251-1475		OS.SE.1250-1.E	5.3	MK.250-0	9.1			SBA.H...	11.1	1x	
	1476-1500		OS.SE.1025-1.E	5.3	MK.250-1	9.1	ZSRE SL	9.6	SBA.H...	11.1	2x	
	1501-1725		OS.SE.1250-1.E	5.3	MK.250-1	9.1	ZSRE SL	9.6	SBA.H...	11.1	2x	
381-1725	511-2725		E1.SE	4.2	SH.IF-N.E...	7.2			SBA.H...	11.1	1x	
481-1020	231-510		E1.SE	4.2	SH.IF-N.E...	7.2			SBA.H...	11.1	1x	
	381-1725	1061-1485	M.500-1	9.2					SBA.H...	11.1	1x	
		1486-1735	M.750-1	9.2					SBA.H...	11.1	1x	
		1736-2235	MK.750-1	9.1	M.500-1	9.2			SBA.H...	11.1	2x	
		2236-2485	MK.750-1	9.1	M.750-1	9.2			SBA.H...	11.1	2x	
		2486-2725	MK.750-1	9.1	MK.750-1	9.1	M.500-1	9.2	SBA.H...	11.1	3x	
	481-1020	231-510	FL.IF-N...	6.1	EL.H.IF-N...	6.5						
	381-1725	511-2725	FL.IF-N...	6.1	EL.H.IF-N...	6.5						
	1041-1450	231-2725	M.500-1	9.2					SBA.H...	11.1	1x	
	1451-1725		M.750-1	9.2					SBA.H...	11.1	1x	
	381-1725	511-2725	E1	4.1					SBS.H...	11.3	1x	
	481-1020	231-510	E3	4.3					SBS.H...	11.3	1x	

In case of sash rebate heights (FFH) of < 711 mm it is not possible to install a fail-safe device directly onto the drive rod. By combining a shorter drive rod with an MK.250.FSF interlocking rod, the required fail-safe device can be integrated from a sash rebate height of > 475 mm.

 marks a line with items that are always used, regardless of size

Tilt fanlight

Basic equipment

9 mm and 13 mm groove centre position



2

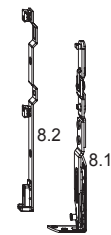
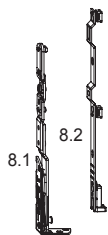
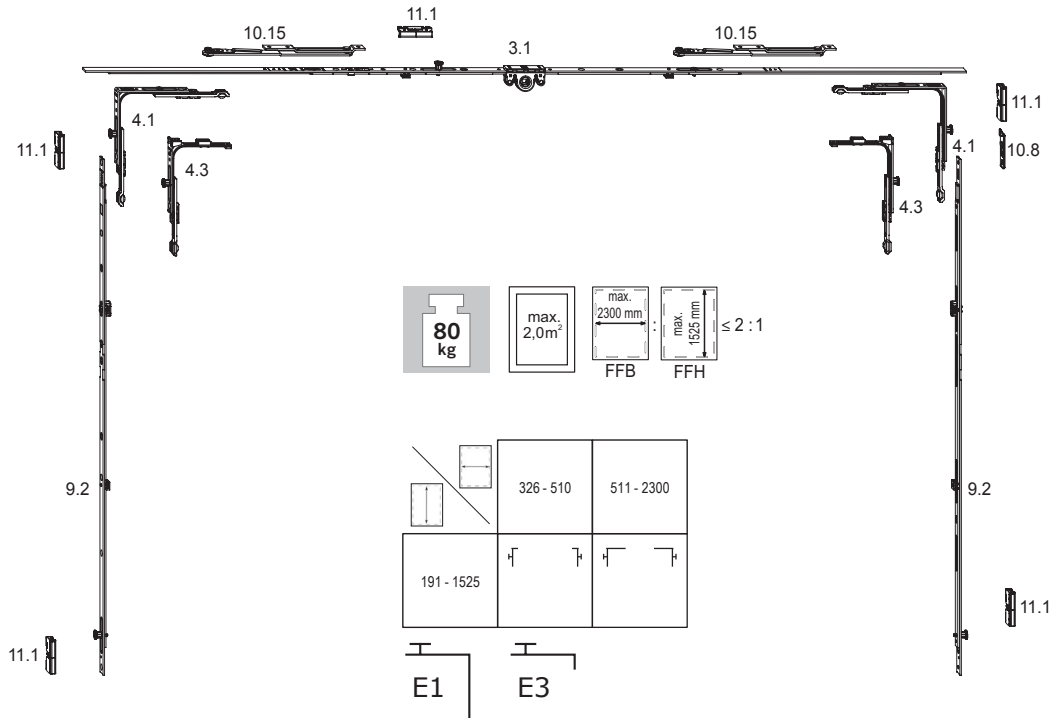

The shown distance between locking points is 1000 mm.











The locking distance to be used is the responsibility of the window manufacturer.

Tilt fanlight

Basic equipment

9 mm and 13 mm groove centre position



				Pos.		Pos.		Pos.		Pos.	
	326-710	191-1525	GAM.800	3.1	GRT FSR SL	10.15					
	711-1050		GAM.1050-1	3.1	GRT FSR SL	10.15			SBA.H...	11.1	1x
	1051-1400		GAM.1400-1	3.1	GRT FSR SL	10.15	GRT FSR SL	10.15	SBA.H...	11.1	1x
	1401-1800		GAM.1800-2	3.1	GRT FSR SL	10.15	GRT FSR SL	10.15	SBA.H...	11.1	2x
	1801-2300		GAM.2300-3	3.1	GRT FSR SL	10.15	GRT FSR SL	10.15	SBA.H...	11.1	3x
	326-510	191-1525	E3	4.3					SBA.H...	11.1	1x
	511-2300		E1	4.1					SBA.H...	11.1	1x
	326-2300	 191-1525	DL.H.IF-N...LS	8.1	DLS.IF...	8.2					
		1061-1485	M.500-1	9.2					SBA.H...	11.1	1x
		1486-1525	M.750-1	9.2					SBA.H...	11.1	1x
	741-1480	191-1525	ZV-FT SL	11.4					ZV-RT.H...	11.5	1x
	1481-2300		ZV-FT SL	11.4	ZV-FT SL	11.4			ZV-RT.H...	11.5	2x
	326-2300	 191-1525	DL.H.IF-N...RS	8.1	DLS.IF...	8.2					
		1061-1485	M.500-1	9.2					SBA.H...	11.1	1x
		1486-1525	M.750-1	9.2					SBA.H...	11.1	1x
	 326-2300	191-1525	AWDR SL	10.8							
	326-510		E3	4.3					SBA.H...	11.1	1x
	511-2300		E1	4.1					SBA.H...	11.1	1x

211151 32019

- To secure the tilting sash in 90° opening position, or during cleaning, the window must also be fitted with standard cleaning or supporting shears.
- The sashes must be secured in the cleaning position in such a way that no unacceptable forces are exerted on the hinges.
- After cleaning the window, the rebate shear must be properly attached and secured.
- Close windows in case of wind and draft. Move the fitting to locking position

 marks a line with items that are always used, regardless of size

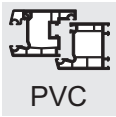

PVC

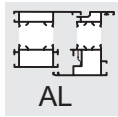

AL

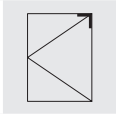
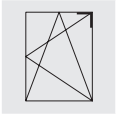

4

Corner drive E1.SE.N

- Utilisation in combination with the shears
SH.SE / SA.SE / SK.SE and SH.IF / SA.IF / SK.IF
- Bracket length 98.5 mm
- Automatic and manual assembly possible
- Smooth operation, due to rust-free spring steel hinges inserted in C-rail
- With supporting element to fix in the fitting groove of the sash

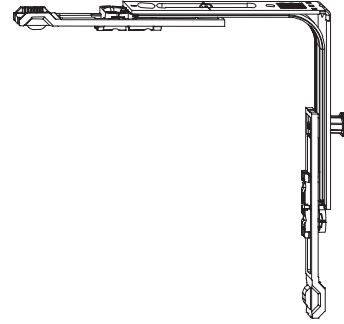

E1.SE.N

Item designation	Item no.		VPA1 Pcs/type	VPA2 Pcs/type
E1.SE.N	5060652	4	100 KK	2400 EK

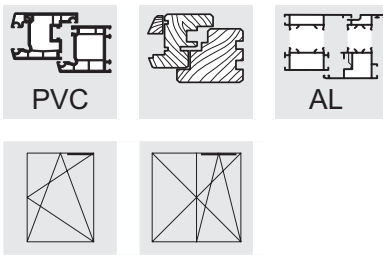

Top rod OS.SE

- In combination with shears S...SE / S...IF / S...IF-N
- After assembly the top rod and the shear are firmly attached to one another
- From 1475 mm sash rebate width with additional shear ZSR
- Clampable in fitting groove

Top rod OS.SE...E

- For the type of fitting "Tilt before turn"
- In combination with shears S...SE.E / S...IF.E / S...IF-N.E
- From 1475 mm sash rebate width with additional shear ZSRE
- Other details regarding the design see above

Item designation	Item no.	Application range		VPA1 Pcs/type	VPA2 Pcs/type
OS.SE.550	4934243	FFB 480 550	3	20 BD	800 EA
OS.SE.800	4934244	FFB 550 800	4	20 BD	800 EA
OS.SE.1025-1	4934245	FFB 775 1025	5	20 BD	500 EA
OS.SE.1250-1	4934246	FFB 1000 1250	6	20 BD	500 EA
OS.SE.550.E	5003250	FFB 480 550	3	20 BD	800 EA
OS.SE.800.E	5003251	FFB 550 800	4	20 BD	800 EA
OS.SE.1025-1.E	5003252	FFB 775 1025	5	20 BD	500 EA
OS.SE.1250-1.E	5003253	FFB 1000 1250	6	20 BD	500 EA

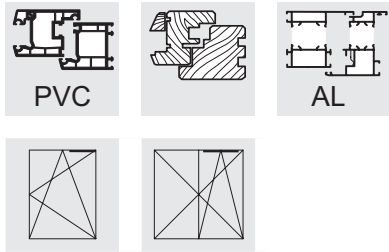

5

Top rod OS.SE...E1.SE.F

- Top rod OS.SE... with pre-connected E1.SE for efficient assembly by means of screwing machines
- In combination with shears S...SE / S...IF / S...IF-N
- After assembly the top rod and the shear are firmly attached to one another
- From 1475 mm sash rebate width with additional shear ZSR

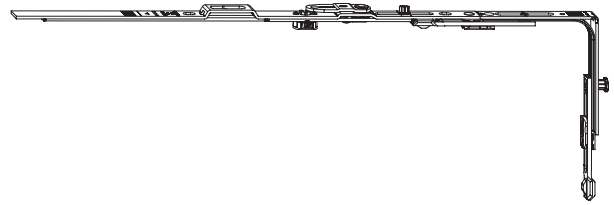

Top rod OS.SE...E1.ZSS

- With pre-assembled anti-slam device

Top rod OS.SE...E.ZSS.E1.SE.F

- For the type of fitting "Tilt before turn"
- With pre-assembled anti-slam device
- In combination with shears S...SE.E / S...IF.E / S...IF-N.E
- From 1475 mm sash rebate width with additional shear ZSRE

Item designation	Item no.	Application range		VPA1 Pcs/type	VPA2 Pcs/type
OS.SE.550.E1.SE.F	4942498	FFB 480 550	5	10 BD	400 EA
OS.SE.800.E1.SE.F	4942499	FFB 550 800	5	10 BD	400 EA
OS.SE.1025-1.E1.SE.F	4942500	FFB 775 1025	6	10 BD	400 EA
OS.SE.1250-1.E1.SE.F	4942501	FFB 1000 1250	6	10 BD	400 L1
OS.SE.550.E1.SE.ZSS.F	5025778	FFB 480 550	5	10 BD	400 EA
OS.SE.800.E1.SE.ZSS.F	5025779	FFB 550 800	5	10 BD	400 EA
OS.SE.1025-1.E1.SE.ZSS.F	5025780	FFB 775 1025	6	10 BD	400 EA
OS.SE.1250-1.E1.SE.ZSS.F	5025781	FFB 1000 1250	6	10 BD	400 L1
OS.SE.550.E.ZSS.E1.SE.F	5049407	FFB 480 550	5	10 BD	400 EA
OS.SE.800.E.ZSS.E1.SE.F	5049409	FFB 550 800	5	10 BD	400 EA
OS.SE.1025-1.E.ZSS.E1.SE.F	5049411	FFB 775 1025	6	10 BD	400 EA
OS.SE.1250-1.E.ZSS.E1.SE.F	5049412	FFB 1000 1250	6	10 BD	400 L1

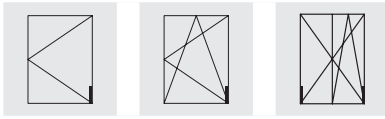

Corner hinges EL.H.IF-N

- In combination with sash hinge FL.IF-N
- Pressure adjustment: +/- 0.8 mm
- Sash weight max. 130 kg
- Max. Opening angle 95°
- Rebate shape see Group 15, installation drawings B-11-...

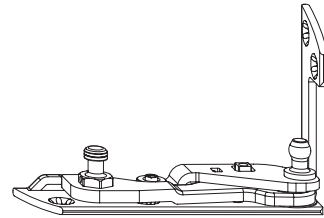

6

Corner hinge EL.H.IF-N.29-13-12 ...

- as described above, but
- component depth 29 mm
- Airgap 12 mm

Corner hinge EL.H.IF-N.29-13-13 ...

- as described above, but
- component depth 29 mm
- Lateral airgap 13 mm

Note:

- Please observe the specifications concerning screw fixing of hinge parts that are given in the mounting instructions!

Item designation	Item no.	Application range		Groove centre position	Max. sash weight (kg)	VPA1 Pcs/type	VPA2 Pcs/type
EL.H.IF-N.24-9.RS	5101741	EF ≥ 24 mm	6	9 mm	130	50 KK	400 EK
EL.H.IF-N.24-9.LS	5101742	EF ≥ 24 mm	6	9 mm	130	50 KK	400 EK
EL.H.IF-N.24-13.RS	5101745	EF ≥ 24 mm	6	13 mm	130	50 KK	400 EK
EL.H.IF-N.24-13.LS	5101746	EF ≥ 24 mm	6	13 mm	130	50 KK	400 EK
EL.H.IF-N.29-13-12.RS	5101753	EF ≥ 29 mm	6	13 mm	130	50 KK	400 EK
EL.H.IF-N.29-13-12.LS	5101754	EF ≥ 29 mm	6	13 mm	130	50 KK	400 EK
EL.H.IF-N.29-13-12.Z.8-12.RS	5101755	EF ≥ 29 mm	6	13 mm	130	50 KK	400 EK
EL.H.IF-N.29-13-12.Z.8-12.LS	5101756	EF ≥ 29 mm	6	13 mm	130	50 KK	400 EK
EL.H.IF-N.29-13-13.RS	5101749	EF ≥ 29 mm	5	13 mm	130	50 KK	400 EK
EL.H.IF-N.29-13-13.LS	5101750	EF ≥ 29 mm	5	13 mm	130	50 KK	400 EK
EL.H.IF-N.29-13-13.Z.8-2.RS	5101751	EF ≥ 29 mm	5	13 mm	130	50 KK	400 EK
EL.H.IF-N.29-13-13.Z.8-2.LS	5101752	EF ≥ 29 mm	5	13 mm	130	50 KK	400 EK

EF = standard rebate
RS = right, LS = left

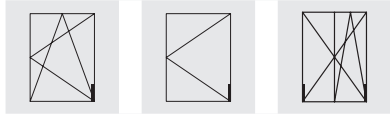
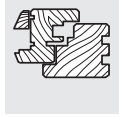

Sash hinges FL.IF-N

- For 13 mm eurogroove position
- Sash weight max. 130 kg
- Height adjustment +2 mm / 1.5 mm
- Side adjustment +2.5 mm / 2.5 mm
- Used in combination with corner hinge EL...IF-N

Sash hinge FL.IF-N.C

- As described above, but as clampable version for automatic screwing

Sash hinge FL.IF-N.9

- As described above, but for 9 mm groove centre position
- Can be used left and right hand



Item designation	Item no.		Groove centre position	Max. sash weight (kg)	VPA1 Pcs/type	VPA2 Pcs/type
FL.IF-N.RS	5100821	4	13 mm	130	50 KK	400 EK
FL.IF-N.LS	5100822	4	13 mm	130	50 KK	400 EK
FL.IF-N.C.RS	5100825	4	13 mm	130	50 KK	400 EK
FL.IF-N.C.LS	5100826	4	13 mm	130	50 KK	400 EK
FL.IF-N.9	5103026	4	9 mm	130	50 KK	400 EK

RS = right, LS = left

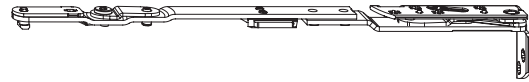
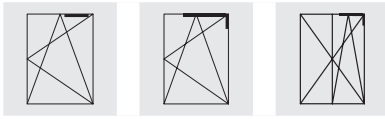

Shears SH.IF-N

- When sash is closed, it is completely concealed with no hinges visible
- Only one shear size
- Max. Opening angle 95°
- Used with Top Rod OS.SE
- Contact pressure adjustment in the shear area is performed via E1.SE
- Adjustment to raise the sash 2.5 mm and lower it 1.5 mm
- Rebate shape see Group 15, installation drawings B-11-...

7

Shear SH.IF-N.29-13-12 ...

- as described above, but
- component depth 29 mm
- Airgap 12 mm

Shear SH.IF-N.29-13-13 ...

- as described above, but
- component depth 29 mm
- Lateral airgap 13 mm

Shear SK.IF-N.E...

- Tilt before turn
- Used in combination with top rod OS.SE.E

Note:

- Please observe the specifications concerning screw fixing of hinge parts that are given in the mounting instructions!

Item designation	Item no.	Application range		Groove centre position	Max. sash weight (kg)	VPA1 Pcs/type	VPA2 Pcs/type	VPA3 Pcs/type
SH.IF-N.24-9.RS	5101761	EF ≥ 24 mm	6	9 mm	130	10 BD	60 GK	240 EK
SH.IF-N.24-9.LS	5101762	EF ≥ 24 mm	6	9 mm	130	10 BD	60 GK	240 EK
SH.IF-N.24-13.RS	5101763	EF ≥ 24 mm	6	13 mm	130	10 BD	60 GK	240 EK
SH.IF-N.24-13.LS	5101764	EF ≥ 24 mm	6	13 mm	130	10 BD	60 GK	240 EK
SH.IF-N.E.24-13.RS	5101767	EF ≥ 24 mm	6	13 mm	130	10 BD	60 GK	240 EK
SH.IF-N.E.24-13.LS	5101768	EF ≥ 24 mm	6	13 mm	130	10 BD	60 GK	240 EK
SH.IF-N.29-13-12.RS	5101769	EF ≥ 29 mm	5	13 mm	130	10 BD	60 GK	240 EK
SH.IF-N.29-13-12.LS	5101770	EF ≥ 29 mm	5	13 mm	130	10 BD	60 GK	240 EK
SH.IF-N.29-13-12.Z.8-12.RS	5101771	EF ≥ 29 mm	5	13 mm	130	10 BD	60 GK	240 EK
SH.IF-N.29-13-12.Z.8-12.LS	5101772	EF ≥ 29 mm	5	13 mm	130	10 BD	60 GK	240 EK
SH.IF-N.29-13-13.RS	5104791	EF ≥ 29 mm	5	13 mm	130		60 GK	240 EK
SH.IF-N.29-13-13.LS	5104792	EF ≥ 29 mm	5	13 mm	130		60 GK	240 EK
SH.IF-N.29-13-13.Z.8-2.RS	5104793	EF ≥ 29 mm	5	13 mm	130		60 GK	240 EK
SH.IF-N.29-13-13.Z.8-2.LS	5104794	EF ≥ 29 mm	5	13 mm	130		60 GK	240 EK

EF = standard rebate
RS = right, LS = left

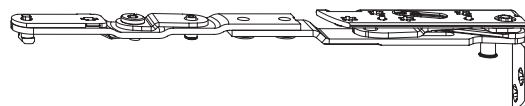
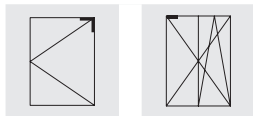

Turn hinge DL.H.IF-N

- Installation on the frame
- Used to hold the turn hinge rail DLS.IF
- When sash is closed, it is completely concealed with no hinges visible
- Max. Opening angle 95°
- Adjustment to raise the sash 2.5 mm and lower it 1.5 mm
- Rebate shape see Group 15, installation drawings B-11-...

8

Turn hinge DL.H.IF-N.29-13-12 ...

- as described above, but
- component depth 29 mm
- Airgap 12 mm

Turn hinge DL.H.IF-N.29-13-13 ...

- as described above, but
- component depth 29 mm
- Lateral airgap 13 mm

Note:

- Please observe the specifications concerning screw fixing of hinge parts that are given in the mounting instructions!

Item designation	Item no.	Application range		Groove centre position	Max. sash weight (kg)	VPA1 Pcs/type	VPA2 Pcs/type	VPA3 Pcs/type
DL.H.IF-N.24-9.RS	5101773	EF ≥ 24 mm	6	9 mm	130	10 BD	60 GK	240 EK
DL.H.IF-N.24-9.LS	5101774	EF ≥ 24 mm	6	9 mm	130	10 BD	60 GK	240 EK
DL.H.IF-N.24-13.RS	5101775	EF ≥ 24 mm	6	13 mm	130	10 BD	60 GK	240 EK
DL.H.IF-N.24-13.LS	5101776	EF ≥ 24 mm	6	13 mm	130	10 BD	60 GK	240 EK
DL.H.IF-N.29-13-12.RS	5101777	EF ≥ 29 mm	5	13 mm	130	10 BD	60 GK	240 EK
DL.H.IF-N.29-13-12.LS	5101778	EF ≥ 29 mm	5	13 mm	130	10 BD	60 GK	240 EK
DL.H.IF-N.29-13-12.Z.8-12.RS	5101779	EF ≥ 29 mm	5	13 mm	130	10 BD	60 GK	240 EK
DL.H.IF-N.29-13-12.Z.8-12.LS	5101780	EF ≥ 29 mm	5	13 mm	130	10 BD	60 GK	240 EK
DL.H.IF-N.29-13-13.RS	5104783	EF ≥ 29 mm	5	13 mm	130	10 BD	60 GK	240 EK
DL.H.IF-N.29-13-13.LS	5104784	EF ≥ 29 mm	5	13 mm	130	10 BD	60 GK	240 EK
DL.H.IF-N.29-13-13.Z.8-2.RS	5104785	EF ≥ 29 mm	5	13 mm	130	10 BD	60 GK	240 EK
DL.H.IF-N.29-13-13.Z.8-2.LS	5104786	EF ≥ 29 mm	5	13 mm	130	10 BD	60 GK	240 EK

EF = standard rebate
RS = right, LS = left

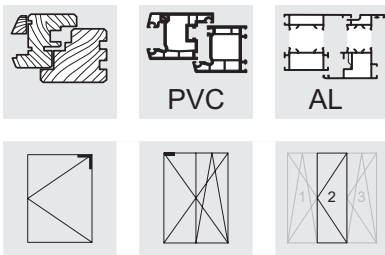

Turn hinge rail DLS.IF

- Used with turn hinge DL...IF-N
- Can be used left and right hand
- Clampable in fitting groove
- Groove centre position 9 mm and 13 mm

Item designation	Item no.		VPA1 Pcs/type	VPA2 Pcs/type	VPA3 Pcs/type
DLS.IF.24-13	5018332	3	10 BD	100 KK	800 EK

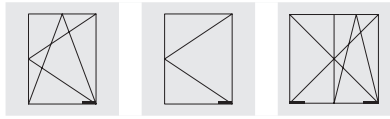

Turn limiter DB.IF

- To prevent window opening too far sideways
- Used with frame connection RA.DB...IF.24-13 for corner hinge EL.H.IF.24-13 / EL.H.IF.24-9
- See Installation Instructions for range of applications of turn limiter
- Can be used left and right hand
- Groove centre position 9 mm and 13 mm

Turn limiter DB.IF.29

- Groove centre position 13 mm
- Used with frame connection RA.DB.H.IF.29-13-12
- Note: Use of the turn limiter depending on installation situation
- Using the turn limiter is imperative if: Reveal depth of surrounding masonry < 120 mm (DIN EN 13126-8, Point 4)

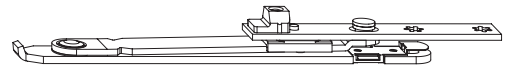

EL...	RA.DB...	DB.IF...
EL.H.IF-N.24-9	RA.DB.H.24-13	DB.IF
EL.H.IF-N.24-13	RA.DB.H.24-13	DB.IF
EL.H.IF-N.29-13-12	RA.DB.H.IF.29-13-12	DB.IF.29
EL.H.IF-N.24-13-13	RA.DB.H.IF.29-13-13	DB.IF.29

10

Item designation	Item no.		Groove centre position	VPA1 Pcs/type	VPA2 Pcs/type	VPA3 Pcs/type
DB.IF	5015697	3	9/13	10 BD	100 KK	800 EK
DB.IF.29	5033118	3	13	10 BD	100 KK	800 EK

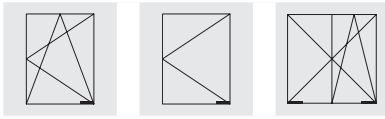

Frame connection RA.DB.H.IF.24-13

- In combination with turn limiter DB.IF and corner hinge EL.H.IF.24...
- See Installation Instructions for range of applications of turn limiter
- Groove centre position 9 mm and 13 mm

Frame connection RA.DB.H.IF.29-13-12

- In combination with corner hinge EL.H.IF.29-13-12
- See Installation Instructions for range of applications of turn limiter
- Groove centre position 13 mm

Frame connection RA.DB.H.IF.29-13-13

- In combination with turn limiter DB.IF.29 and corner hinge EL.H.IF.29-13-13
- See Installation Instructions for range of applications of turn limiter
- Groove centre position 13 mm

EL...	RA.DB...	DB.IF...
EL.H.IF-N.24-9	RA.DB.H.24-13	DB.IF
EL.H.IF-N.24-13	RA.DB.H.24-13	DB.IF
EL.H.IF-N.29-13-12	RA.DB.H.IF.29-13-12	DB.IF.29
EL.H.IF-N.24-13-13	RA.DB.H.IF.29-13-13	DB.IF.29

Item designation	Item no.	Application range		Groove centre position	VPA1 Pcs/type	VPA2 Pcs/type	VPA3 Pcs/type
RA.DB.H.IF.24-13.LS	5077804	EF ≥ 24	3	9/13	50 BL	200 KK	1600 EK
RA.DB.H.IF.24-13.RS	5077802	EF ≥ 24	3	9/13	50 BL	200 KK	1600 EK
RA.DB.H.IF.29-13-12.LS	5088078	EF ≥ 29 mm	3	13	50 BL	200 KK	1600 EK
RA.DB.H.IF.29-13-12.RS	5088077	EF ≥ 29 mm	3	13	50 BL	200 KK	1600 EK
RA.DB.H.IF.29-13-13.LS	5077808	EF ≥ 29 mm	3	13	50 BL	200 KK	1600 EK
RA.DB.H.IF.29-13-13.RS	5077807	EF ≥ 29 mm	3	13	50 BL	200 KK	1600 EK

RS = right, LS = left

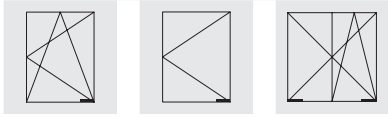

Rebate adapter FA.EL.SH.IF.30

- For backfilling the corner hinge EL.H.IF-N.24... and shear SH.IF-N.24...
- Can be clipped on the hinges
- For 30 mm standard rebate
- Colour: Plastic, black

FA.EL.SH.IF.30.RS

- for corner hinge DIN RS
- for shear DIN LS

FA.EL.SH.IF.30.LS

- for corner hinge DIN LS
- for shear DIN RS

Rebate adapter FA.RA.DB.IF.30

- For 30 mm standard rebate
- For backfilling the frame connection

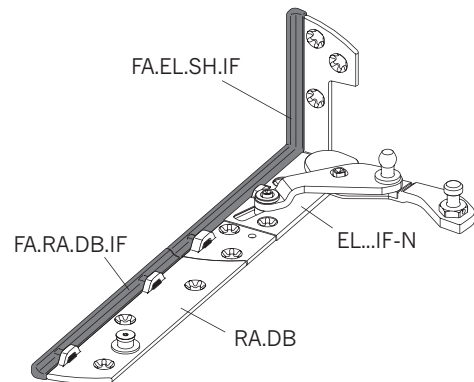
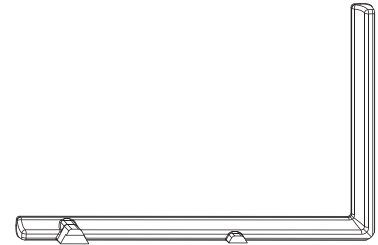

10

Item designation	Item no.	VPA1 Pcs/type	VPA2 Pcs/type	VPA3 Pcs/type
FA.EL.SH.IF.30.LS	5033680	50 BL	400 KK	3200 EK
FA.EL.SH.IF.30.RS	5033659	50 BL	400 KK	3200 EK
FA.RA.DB.IF.30.LS	5033682	25 BL	400 KK	3200 EK
FA.RA.DB.IF.30.RS	5033681	25 BL	400 KK	3200 EK

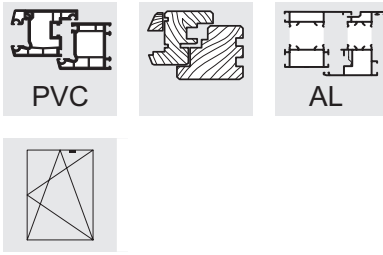

Accessories top rod OS.SE

Anti-Slam Device ZSS OP

- Prevents tilted windows slamming shut in case of light draughts and low window sashes
- For inserting into Top Rod OS.SE
- Can be used left and right hand
- Colour: white

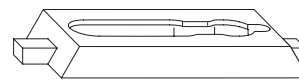

ZSS OP

Tilt limiter KBG.OS.SE

- Reduces tilt opening width by approx. 50 mm
 - For inserting into Top Rod OS.SE
 - Can be used left and right hand
-
- Recommendation for use: unfavourable sash formats, e. g.
 - KBG.OS.SE1 for sash rebate heights < 600 mm
 - KBG.OS.SE2 for sash rebate heights < 800 mm

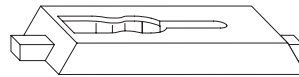

KBG.OS.SE

Item designation	Item no.	VPA1 Pcs/type	VPA2 Pcs/type	VPA3 Pcs/type
ZSS OP WS	2763095	100 BL	1000 KK	8000 EK
KBG.OS.SE.1	4969389	100 BL	1000 KK	8000 EK
KBG.OS.SE.2	4969390	100 BL	1000 KK	8000 EK

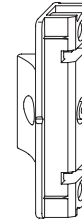
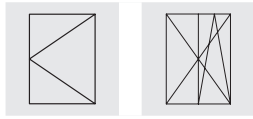

Claw bolt

- Centre lock for turn and double sashes
- Combination of frame component ZV-RT and sash component ZV-FT
- Adjustable for airgaps of 11 to 14 mm
- For left and right hand operation
- Rebate shape see Group 15, installation drawings B-11-...

Claw bolt ZV-RT

- Frame part to screw on
- Profile dependent see Group 11, Frame Parts

Claw bolt ZV-FT

- Counter piece for ZV-RT
- Is fixed in the fitting groove hinge side
- Adjustment of contact pressure by means of an Allen key

10

Item designation	Item no.		Groove centre position	Rebate shape	VPA1 Pcs/type	VPA2 Pcs/type	VPA3 Pcs/type
ZV-RT.H.9-18.AGR	4941342	2	9	EF≥18	500 KK	4000 EK	
ZV-RT.H.9-20.AGR	4941343	2	9	EF≥20	500 KK	4000 EK	
ZV-RT.H.9-6-8.AGR	4941344	2	9	EN6/8	500 KK	4000 EK	
ZV-RT.H.9-7-8.AGR	4941345	2	9	EN7/8	500 KK	4000 EK	
ZV-RT.H.13-24.AGR	4941347	2	13	EF≥24	500 KK	4000 EK	
ZV-RT.H.13-29.AGR	4941360	2	13	EF≥29	500 KK	4000 EK	
ZV-RT.H.13-30.AGR	4941362	2	13	EF≥30	500 KK	4000 EK	
ZV-RT.H.13-Z.8-32.AGR	4941348	2	13	EF≥24	500 KK	4000 EK	
ZV-FT SL	2359324	2	9/13		10 BL	100 KK	800 EK

EF = standard rebate
EN = eurogroove

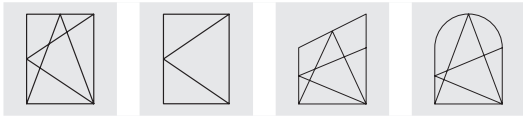

Keep SBA.H.9-...

- For 12 mm airgap
- For 9 mm eurogroove position
- Standard keep made of zinc diecast
- Used to hold frame part DFE/TFE
- Can be used left and right hand
- With 1 diagonal screw connection
- From 25 mm frame rebate depth: with a rear plastic adapter for positioning at the frame rebate
- Rebate shape see Group 15, installation drawings B-11-...
- Keep SB...Z... with positioning plugs

Keep SBA.K.BN

- Utilisation for double-sash windows with opposing euro-groove
- Groove centre position 9 mm and 13 mm

Keep SBA.H.9-20.2G

- For 9 mm eurogroove position
- With 2 vertical screws



Item designation	Item no.		Rebate shape	VPA1 Pcs/type	VPA2 Pcs/type
SBA.H.9-18	4928276	1	EF 18	800 KK	6400 EK
SBA.H.9-20	4928319	1	EF 20	800 KK	6400 EK
SBA.H.9-6-8	4928328	1	EN 6/8	800 KK	6400 EK
SBA.H.9-7-8	4928338	1	EN 7/8	800 KK	6400 EK
SBA.H.Z.8-32	4928119	1	EF > 18	800 KK	6400 EK
SBA.H.9-25	4934956	1	EF 25	200 KK	1600 EK
SBA.H.9-25.Z19	4935862	2	EF>25	400 KK	3200 EK
SBA.H.9-26	4989924	1	EF 26	200 KK	1600 EK
SBA.H.9-27	4934958	1	EF 27	200 KK	1600 EK
SBA.H.9-28	4989925	1	EF 28	200 KK	1600 EK
SBA.H.9-29	4934961	1	EF 29	200 KK	1600 EK
SBA.H.9-30	4934962	1	EF 30	200 KK	1600 EK
SBA.K.BN	5061213	1	BN	500 KK	4000 EK
SBA.H.9-20.2G	5009816	2	EF 20	800 K3	6400 E3

EF = standard rebate
 EN = eurogroove
 BN = fitting groove double sash

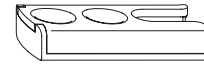
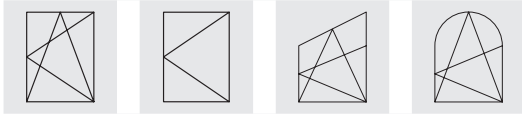

Security keep SBS.H.9-...

- For 9 mm eurogroove position
- Security keep
- Steel web with PVC bottom part
- With two diagonal screw connections
- Rebate shape see Group 15, installation drawings B-11-...
- Keep SB...Z... with positioning plugs

Item designation	Item no.	Application range		Rebate shape	VPA1 Pcs/type	VPA2 Pcs/type
SBS.H.9-18.LS	4928310	Std	2	EF 18	400 KK	3200 EK
SBS.H.9-18.RS	4928278	Std	2	EF 18	400 KK	3200 EK
SBS.H.9-20.LS	4928321	Std	2	EF 20	400 KK	3200 EK
SBS.H.9-20.RS	4928320	Std	2	EF 20	400 KK	3200 EK
SBS.H.9-7-8.LS	4928340	Std	2	EN 7/8	400 KK	3200 EK
SBS.H.9-7-8.RS	4928339	Std	2	EN 7/8	400 KK	3200 EK
SBS.H.Z.8-32.LS	4928139	Std	2	EF > 18	400 KK	3200 EK
SBS.H.Z.8-32.RS	4928138	Std	2	EF > 18	400 KK	3200 EK

EF = standard rebate
 EN = eurogroove
 Std = basic safety
 RS = right, LS = left

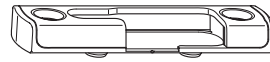
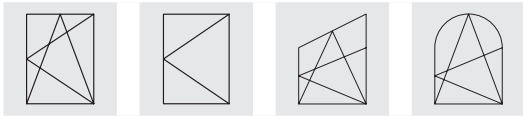

Security keep SBS.H.9-... .WK

- For 9 mm eurogroove position
- Steel web with PVC bottom part
- With two diagonal screw connections
- Rebate shape see Group 15, installation drawings B-11-...
- Keep SB...Z... with positioning plugs
- If DFE/TFE element is used, a frame part RT.DFE-TFE.H.WK is required.

Item designation	Item no.	Application range		Rebate shape	VPA1 Pcs/type	VPA2 Pcs/type
SBS.H.9-18.LS.WK	4983433	Std	2	EF 18	200 KK	1600 EK
SBS.H.9-18.RS.WK	4983434	Std	2	EF 18	200 KK	1600 EK
SBS.H.9-20.LS.WK	4993749	Std	2	EF 20	200 KK	1600 EK
SBS.H.9-20.RS.WK	4993748	Std	2	EF 20	200 KK	1600 EK
SBS.H.9-6-8.LS.WK	4983437	Std	2	EN 6/8	200 KK	1600 EK
SBS.H.9-6-8.RS.WK	4983439	Std	2	EN 6/8	200 KK	1600 EK
SBS.H.9-7-8.LS.WK	4983440	Std	2	EN 7/8	200 KK	1600 EK
SBS.H.9-7-8.RS.WK	4983441	Std	2	EN 7/8	200 KK	1600 EK
SBS.H.Z.8-32.LS.WK	4983442	Std	2	EF > 18	200 KK	1600 EK
SBS.H.Z.8-32.RS.WK	4983443	Std	2	EF > 18	200 KK	1600 EK

EF = standard rebate
 EN = eurogroove
 Std = basic safety
 RS = right, LS = left

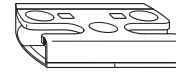
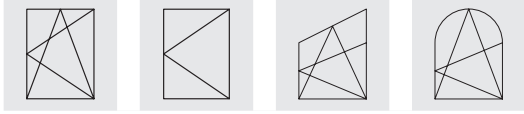

Security keep SBS.H.9-... Rebate depth ≥ 25 mm

- For 9 mm eurogroove position
- Security keeps for deeper rebates of 25 mm and more
- Steel web with PVC bottom part
- With two straight screw connections and one diagonal screw connection
- Rebate shape see Group 15, installation drawings B-11-...
- Keep SB...Z... with positioning plugs
- Can be used left and right hand

Item designation	Item no.	Application range		Rebate shape	VPA1 Pcs/type	VPA2 Pcs/type
SBS.H.9-25	4995790	Std	3	EF 25	400 KK	3200 EK
SBS.H.9-25.Z19	4935858	Std	3	EF>25	400 KK	3200 EK
SBS.H.9-26	4990383	Std	3	EF 26	400 KK	3200 EK
SBS.H.9-27	4995792	Std	3	EF 27	400 KK	3200 EK
SBS.H.9-28	4936038	Std	3	EF 28	400 KK	3200 EK
SBS.H.9-29	4936039	Std	3	EF 29	400 KK	3200 EK
SBS.H.9-30	4936050	Std	3	EF 30	400 KK	3200 EK

EF = standard rebate
Std = basic safety

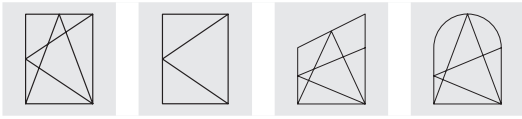

Security tilt keep SBK.H.9-...

- For 9 mm eurogroove position
- Steel web with PVC bottom part
- With two diagonal screw connections
- Rebate shape see Group 15, installation drawings B-11-...
- Keep SB...Z... with positioning plugs

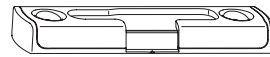

Rotation Stop Set GRT.DS-SBK.H...

- Security keep with integrated rotation stop
- Lockable with special key
- In locked state the sash cannot be turned
- Installation situation see group 15, installation drawings B-11-10
- The key SLUE DS SL must be ordered separately.

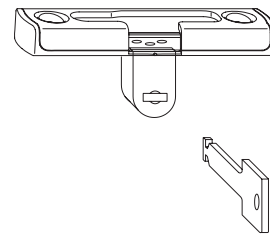

Security tilt keep SBK.H...KVD (Tilt First)

- Use in turn-tilt windows with operating sequence tilt before turn
- For 9 mm eurogroove position
- Can be used left and right hand

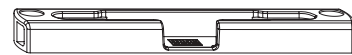

Item designation	Item no.	Application range		Rebate shape	VPA1 Pcs/type	VPA2 Pcs/type	VPA3 Pcs/type
SBK.H.9-18.LS	4928313	Std	2	EF 18	200 KK	1600 EK	
SBK.H.9-18.RS	4928311	Std	2	EF 18	200 KK	1600 EK	
SBK.H.9-20.LS	4928324	Std	2	EF 20	200 KK	1600 EK	
SBK.H.9-20.RS	4928323	Std	2	EF 20	200 KK	1600 EK	
SBK.H.9-7-8.LS	4928342	Std	2	EN 7/8	200 KK	1600 EK	
SBK.H.9-7-8.RS	4928341	Std	2	EN 7/8	200 KK	1600 EK	
SBK.H.Z.8-32.LS	4928141	Std	2	EF > 18	200 KK	1600 EK	
SBK.H.Z.8-32.RS	4928140	Std	2	EF > 18	200 KK	1600 EK	
GRT.DS-SBK.H.9-18.LS	4949467	Std	2	EF ≥ 18	10 BL	50 KK	
GRT.DS-SBK.H.9-18.RS	4949466	Std	2	EF ≥ 18	10 BL	50 KK	
SLUE DS SL	1846868				10 BL	1000 KK	8000 EK
SBK.H.9-18.KVD	4986929	Std	2	EF ≥ 18	200 KK	1600 EK	

EF = standard rebate
 EN = eurogroove
 Std = basic safety
 RS = right, LS = left

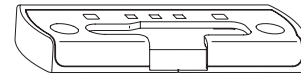
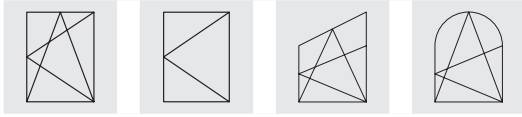

Security tilt keep SBK.H.9-... Rebate depth ≥ 25 mm

- For 9 mm eurogroove position
- Security keeps for deeper rebates of 25 mm and more
- Steel web with PVC bottom part
- With two diagonal screw connections
- Rebate shape see Group 15, installation drawings B-11-...
- Keep SB...Z... with positioning plugs

Security tilt keep for low thresholds

SBK.H.9.WEV.BS

- The components specially developed for thresholds (sash and frame side) can be found in the catalogue "activPilot supplementary range of threshold components..."

Item designation	Item no.	Application range		Rebate shape	VPA1 Pcs/type	VPA2 Pcs/type
SBK.H.9-25.LS	4936052	Std	2	EF 25	200 KK	1600 EK
SBK.H.9-25.RS	4936051	Std	2	EF 25	200 KK	1600 EK
SBK.H.9-25.Z19.LS	4935861	Std	2	EF>25	200 KK	1600 EK
SBK.H.9-25.Z19.RS	4935860	Std	2	EF>25	200 KK	1600 EK
SBK.H.9-26.LS	4936054	Std	2	EF 26	200 KK	1600 EK
SBK.H.9-26.RS	4936053	Std	2	EF 26	200 KK	1600 EK
SBK.H.9-27.LS	4936056	Std	2	EF 27	200 KK	1600 EK
SBK.H.9-27.RS	4936055	Std	2	EF 27	200 KK	1600 EK
SBK.H.9-28.LS	4936058	Std	2	EF 28	200 KK	1600 EK
SBK.H.9-28.RS	4936057	Std	2	EF 28	200 KK	1600 EK
SBK.H.9-29.LS	4936061	Std	2	EF 29	200 KK	1600 EK
SBK.H.9-29.RS	4936059	Std	2	EF 29	200 KK	1600 EK
SBK.H.9-30.LS	4936063	Std	2	EF 30	200 KK	1600 EK
SBK.H.9-30.RS	4936062	Std	2	EF 30	200 KK	1600 EK

EF = standard rebate
Std = basic safety
RS = right, LS = left

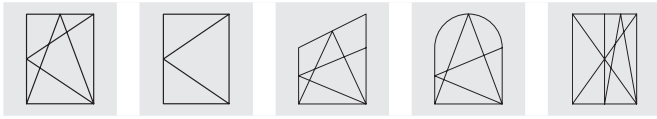

Keep SBA.H.

- For 12 mm airgap
- For 13 mm eurogroove position
- Standard keep made of zinc diecast
- Used to hold frame part DFE/TFE
- Can be used left and right hand
- With 1 diagonal screw connection
- Rebate shape see Group 15, installation drawings B-11-...
- Keep SB...Z... with positioning plugs



Keep SBA.K.BN

- Utilisation for double-sash windows with opposing euro-groove
- Groove centre position 9 mm and 13 mm



Keep SBA.H.13-24.2G

- For 13 mm eurogroove position
- With 2 vertical screws

Item designation	Item no.		Rebate shape	Groove centre position	VPA1 Pcs/type	VPA2 Pcs/type
SBA.H.13-24	4940185	1	EF24	13	800 KK	19200 EK
SBA.H.13-29	4939513	1	EF29	13	400 KK	3200 EK
SBA.H.13-29.Z	4952608	1	EF≥29	13	400 KK	3200 EK
SBA.H.13-30	4939510	1	EF30	13	400 KK	3200 EK
SBA.K.BN	5061213	1	BN	9/13	500 KK	4000 EK
SBA.H.13-24.2G	5009815	2	EF24	13	800 K3	6400 E3

EF = standard rebate
 BN = fitting groove double sash

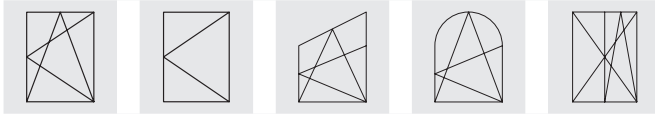

Security keep SBS.H.13-...

- For 13 mm eurogroove position
- Steel web with PVC bottom part
- With two straight screw connections and one diagonal screw connection
- Rebate shape see Group 15, installation drawings B-11-...

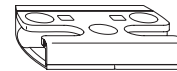

Security keep SBS.H.13-24

- As above, however there are only two diagonal screw connections
- If DFE/TFE element is used, a frame part RT.DFE-TFE.H.WK is required.
- Cannot be used on the corner drive next to shear

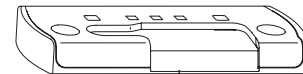

Tilt element SBK.H.E

- Coupled with SBS.H.13... keep it forms the tilt element for 'tilt before turn' switch sequence.
- For 13 mm eurogroove position
- Frame rebate depth min. 29 mm

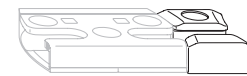

Item designation	Item no.	Application range		Rebate shape	VPA1 Pcs/type	VPA2 Pcs/type
SBS.H.13-29	4939537	Std, RC2	3	EF29	400 KK	3200 EK
SBS.H.13-30	4939538	Std, RC2	3	EF30	400 KK	3200 EK
SBS.H.13-24 LS	4940161	Std, RC2	2	EF24	200 KK	1600 EK
SBS.H.13-24 RS	4940160	Std, RC2	2	EF24	200 KK	1600 EK
SBK.H.E.29-13	4942839	Std, RC2	1	EF29/30	200 KK	1600 EK

EF = standard rebate
 Std = basic safety
 RC2 = RC2 compliant
 RS = right, LS = left

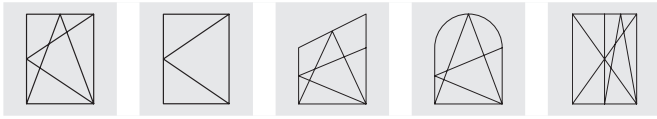

Security tilt keep SBK.H.13-...

- For 13 mm eurogroove position
- Steel web with PVC bottom part
- With two diagonal screw connections
- Rebate shape see Group 15, installation drawings B-11-...

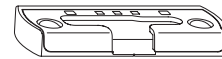

Rotation Stop Set GRT.DS-SBK.H...

- Security keep with integrated rotation stop
- Lockable with special key
- In locked state the sash cannot be turned
- Installation situation see group 15, installation drawings B-11-10
- The key SLUE DS SL must be ordered separately.

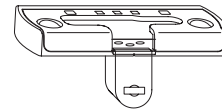

Security keep SBK.H.13-24...KVD (Tilt First)

- For 13 mm eurogroove position
- With 2 straight screw connections
- Rebate shape see Group 15, installation drawings B-11-...
- For operating sequence tilt before turn (Tilt First)



Item designation	Item no.	Application range		Rebate shape	VPA1 Pcs/type	VPA2 Pcs/type	VPA3 Pcs/type
SBK.H.13-24.LS	4940114	Std, RC2	2	EF24	200 KK	1600 EK	
SBK.H.13-24.RS	4940113	Std, RC2	2	EF24	200 KK	1600 EK	
SBK.H.13-29.LS	4939534	Std, RC2	2	EF29	200 KK	1600 EK	
SBK.H.13-29.RS	4939531	Std, RC2	2	EF29	200 KK	1600 EK	
SBK.H.13-30.LS	4939536	Std, RC2	2	EF30	200 KK	1600 EK	
SBK.H.13-30.RS	4939535	Std, RC2	2	EF30	200 KK	1600 EK	
GRT.DS-SBK.H.13-29.LS	4949465	Std, RC2	2	EF ≥ 29mm	10 BL	50 KK	400 EK
GRT.DS-SBK.H.13-29.RS	4949464	Std, RC2	2	EF ≥ 29mm	10 BL	50 KK	400 EK
SLUE DS SL	1846868				10 BL	1000 KK	8000 EK
SBK.H.13-24.LS.KVD	5012612	Std, RC2	2	EF24	200 KK	1600 EK	
SBK.H.13-24.RS.KVD	5012611	Std, RC2	2	EF24	200 KK	1600 EK	

EF = standard rebate
 Std = basic safety
 RC2 = RC2 compliant
 RS = right, LS = left

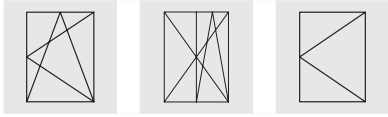

Drill jig LE.B.EL.H.IF/SH.IF/DB.IF

- For positioning the pin holes and predrilling the screw holes of activPilot Topstar shear and corner hinges
- Can be used left and right hand
- Hinge parts with 24 mm depth
- Groove centre position 9 mm and 13 mm

Drilling jig LE.B.IF-H12.EL...29-13

- for corner hinges 29-13-12 mm deep for elements with 12 mm airgap

Drilling jig LE.B.IF-H13.EL...29-13

- for corner hinges 29-13-13 mm deep for elements with 13 mm airgap

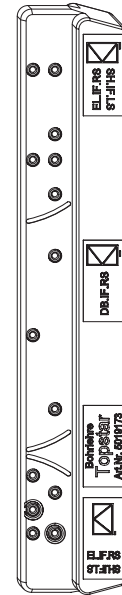

Item designation	Item no.	VPA1 Pcs/type	VPA2 Pcs/type
LE.B.EL.H.IF/SH.IF/DB.IF	5019173	25 KK	200 EK
LE.B.IF-H12.EL/SH/DB.29-13	5090208	25 KK	200 EK
LE.B.IF-H13.EL/SH/DB.29-13	5090209	25 KK	200 EK

General and safety-relevant notices for these mounting instructions

Requirements

The mounting instructions are designed for mounting Winkhaus activPilot fittings for windows and glazed doors only. Fittings are designed for the following sash rebate sizes and sash weights:

- Min. Sash rebate width 380 mm
- Max. Sash rebate width 1725 mm
- From 1475 mm sash rebate width with additional shear ZSR
- Min. Sash rebate height 230 mm
- Max. Sash rebate height 2800 mm
- Max. Sash size 3 m²
- Max. Sash weight 130 kg
- Ratio between sash rebate width: sash rebate height $\leq 2:1$
- Airgap at bottom side 12 +1 mm

Profile design -Timber window

See figure: Wooden profile inside flush Wooden profile inside offset

- Is used for 9 mm and 13 mm groove centre position from a rebate depth of 24 mm
- Suitable for sash weights of up to 130 kg without requiring additional parts for load transfer
- For flush and offset wooden profiles
- Suitable for narrow frames with small free sizes of the frame

When selecting the type of timber please take into account the bulk density and splitting resistance. For softwood profiles it is mandatory to use special screws up to a bulk density of $\leq 450 \text{ kg/m}^3$ (see assembly of frame parts)!



Note: In order to ascertain the permissible sash sizes and sash weights, please refer to the diagrams in the chapter "General Product Information".

The respective overall fitting must be selected from the original fitting components range. Winkhaus accepts no liability if non-original or unauthorised system accessory parts are used.

Persons involved in mounting fittings must have read and understood this fitting guide. Observe production liability information for all work with fittings. Manufacturer will accept no liability in cases of failure to comply with this guide, deployment of insufficiently qualified staff and unauthorised alterations.

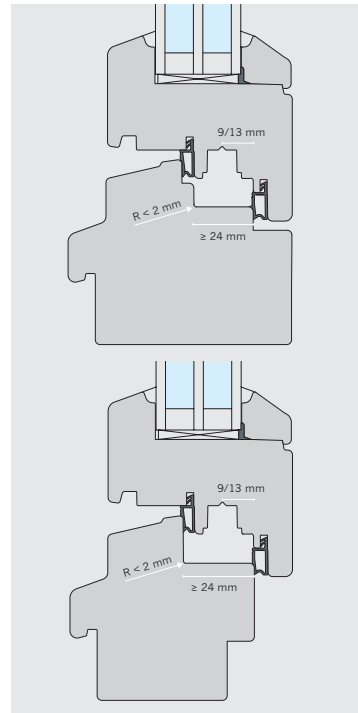

Intended use

Winkhaus activPilot fittings are intended for use in stationary buildings. They are used for opening and closing of windows and patio doors. The elements must be installed perpendicularly and NOT slantwise.



Important: The screw connections of the load-bearing fitting components, such as corner, shear and sash hinges must be performed according to the TBDK guidelines. Adapt the drilling diameter for the fixing screws, the screw diameter and the screw length to the load situation.

Overlap chamfer

If wooden profiles without overlap gasket (particularly windows with small sash rebate heights) are used, the overlap at bottom horizontal position must be chamfered, in order to open the sash into the tilt position.

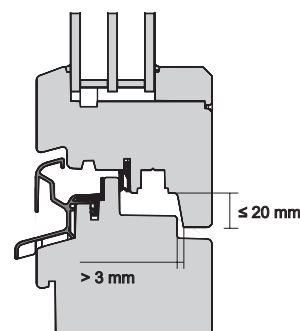

Shortening the fittings

A detailed description on shortening of fittings is available here. This description will be referred to in these assembly instructions.

See figure: Fittings prior to punching

- Always insert the face plate (1) and drive rod (2) perpendicularly from the top with the face plate (1) pointing to the pressure cylinder.

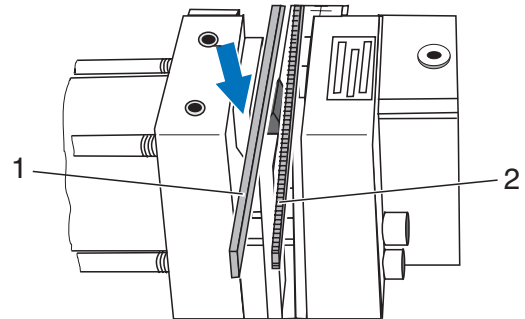

Fittings prior to punching

See figure: Fittings after punching

- After punching, always remove the face plate (1) and drive rod (2) perpendicularly in an upwards direction.

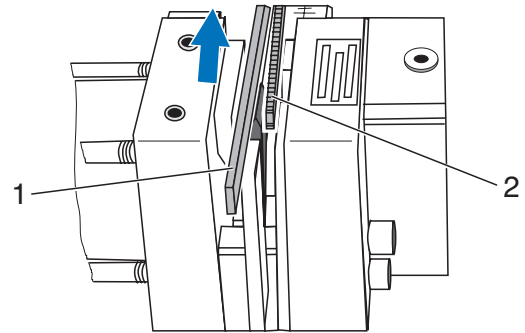

Fittings after punching

See figure: Cleaning the supporting surfaces

- Keep the supporting surfaces (3 and 4) clean.

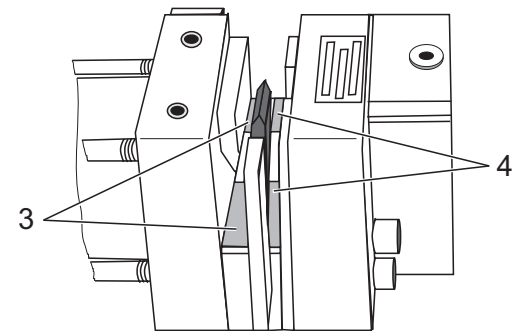

Cleaning the supporting surfaces

Shorten the drive rod GAM (central handle position)

See figure: Marking GAM

- Set measuring value FFH on the measuring device to the GAM mark.

 Please note! If the GAM scale is displaced by one submarking, this corresponds to a longitudinal shift of 2 mm.

See figure: Position for shortening drive rod

- Position the GAM drive rod at the scale; slot drill hole (2) onto bolt (1).
- Turn the GAM drive rod around, and slot the drill hole (3) onto the bolt (1), then trim the other side.
- Shorten the drive rod using the fitting punch.

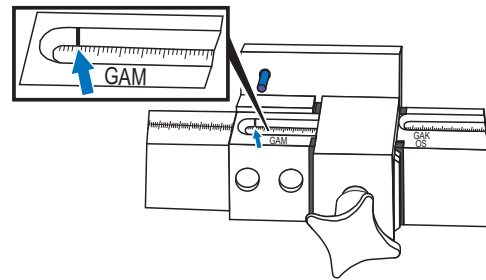

Marking GAM

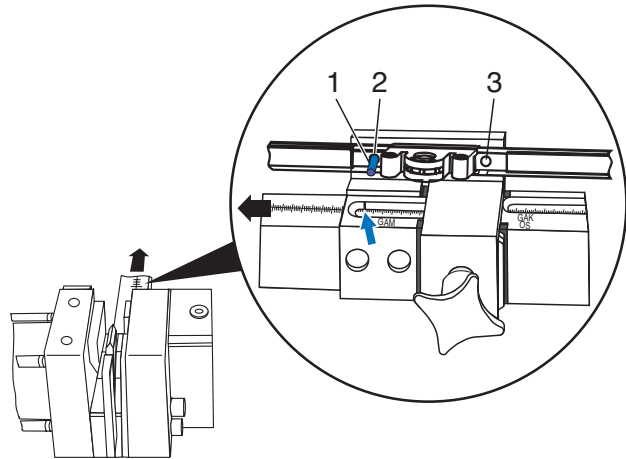

Position for shortening drive rod

Cutting of double sash drive rods GASM

GASM.800

See figure: Cutting instructions GASM

- Adjust the ruler to FFH + 400 mm (example: measured FFH = 567; adjust ruler to 567 mm + 400 mm = 967 mm).
- Connect the drive to the marked hole on the ruler (arrows pointing to cutter).
- Cut off the element.

GASM.1050 GASM.2300

See figure: Cutting instructions GASM

- Adjust the ruler to FFH (sash rebate height).
- Connect the drive to the marked hole on the ruler (arrows pointing to cutter).
- In case of GASM.1050 please make sure that the bolt in the elongated hole is positioned as indicated (red arrow).
- Cut off the element.
- GASM.1050 is always used in combination with corner drive E3.

 Note: The double-sash drive rod must be trimmed before delivery.

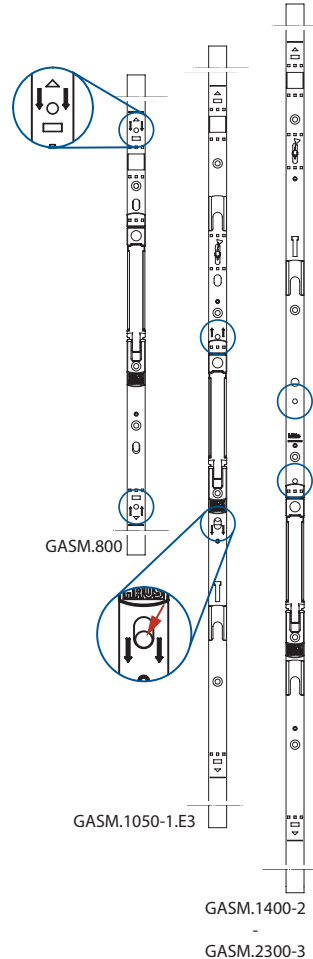

Cutting instructions GASM

Shorten the GAK / GASK drive rod (constant handle position) and top rod OS

i Note: The double-sash drive rod must be trimmed before delivery.

See figure: Markings GAK and OS

- Set the measuring value FFH (GAK/GASK) or FFB (OS) on the measuring device to the GAK/OS mark.

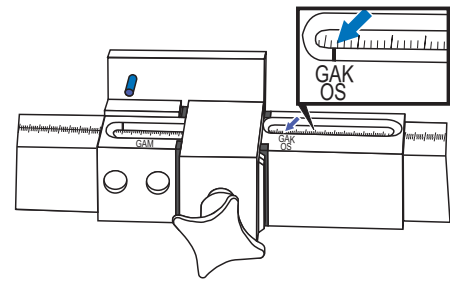

Markings GAK and OS

See figure: Position for shortening drive rod and/or Top rod

- Cutting the top rod OS...
 - Position the drive rod GAK/GASK (fixed handle position) (1) or the top rod OS (1) at the bolt (2).
 - Shorten the drive rod (1) or the top rod (1).

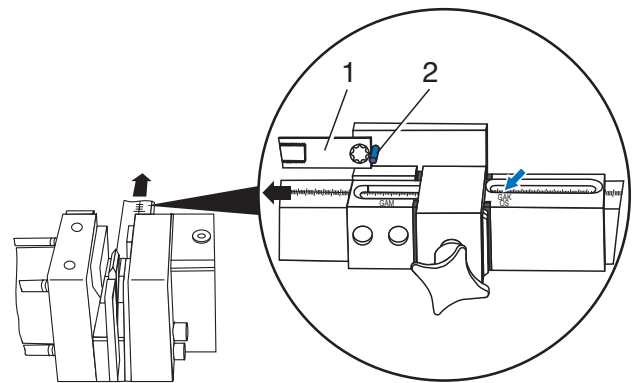

Position for shortening drive rod and/or Top rod

13

Only applies to top rod OS1.600 (OS1.PA.600/OS.XL):

See figure: Position for shortening top rod

- Position the top rod (1) with square holes at bolt (2). At the same time press the offset (see arrow) against the bolt (2).
- Shorten the top rod (1).

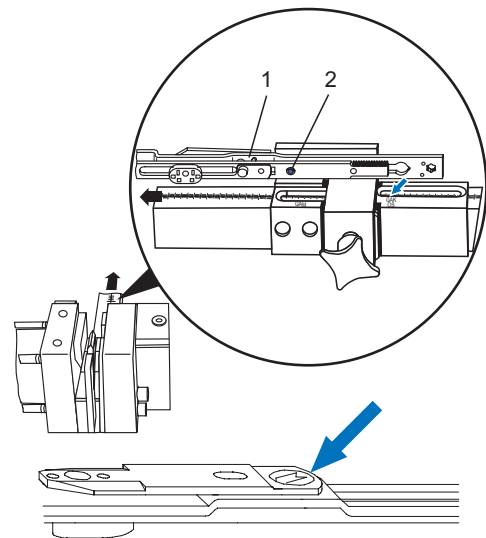

Position for shortening top rod

Mounting of fittings on sash

Rectangular turn window

Prepare the window for fitting.
Then proceed as follows:

i Note: The following figures refer to a window for right hand use. When fitting a window for left-hand use, the figures will be mirror-inverted.

The following also applies:

- When viewing the window from the inside, the symbol is depicted as a full line.
- When viewing the window from the outside, the symbol is depicted as a dotted line.

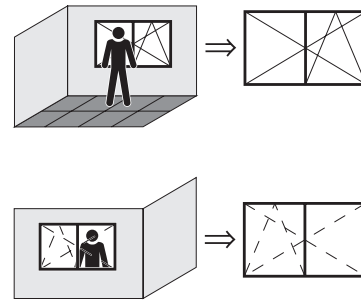

Determine the handle height:

Handle height for drive rod GAM

See figure: Sash rebate height FFH with central handle height GM

If you use a GAM drive rod ... (central handle position), the dimension GM is half the sash rebate height FFH.

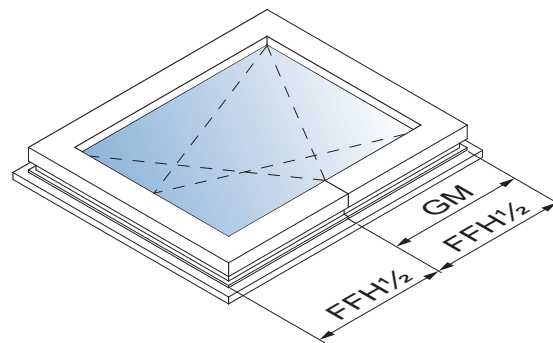

Sash rebate height FFH with central handle height GM

Handle height for drive rod GAK

See figure: Sash rebate height FFH with constant handle position GK

If you use a GAK drive rod ... (constant handle position), dimension GK changes to reflect the sash rebate height FFH. The exact dimensions are specified in the following table.

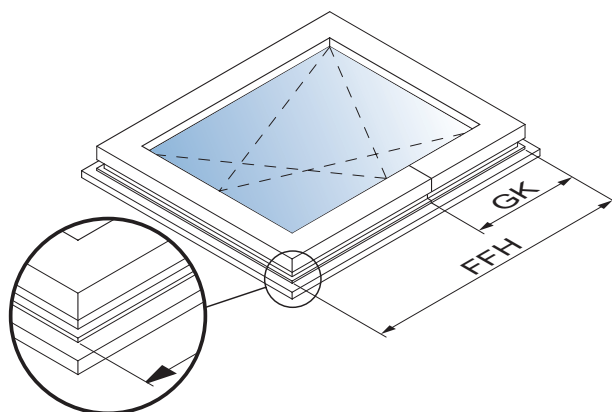

Sash rebate height FFH with constant handle position GK

See figure: Synoptical table: sash rebate height (FFH) / handle position (GK)

The table on the right gives a survey on the handle height (GK) of GAK with regard to the sash rebate height (FFH).

FFH	GK
230 – 324	GK = 114 *
325 – 420	GK = 114 *
421 – 460	GK = 210
461 – 700	GK = 210
701 – 850	GK = 260
851 – 1100	GK = 375
1101 – 1325	GK = 550
1326 – 1525	GK = 550
1526 – 1775	GK = 550
1776 – 2000	GK = 1050
2001 – 2225	GK = 1050

Synoptical table: sash rebate height (FFH) / handle position (GK)
 * Requires the use of E3 corner drive

See figure: Scale drawing "Gear lock" for backset = 15.5 mm

- Drill holes for gear case (ø 12 and ø 25 mm) as per scale drawing.
- Mill the gear housing from the rebate side.

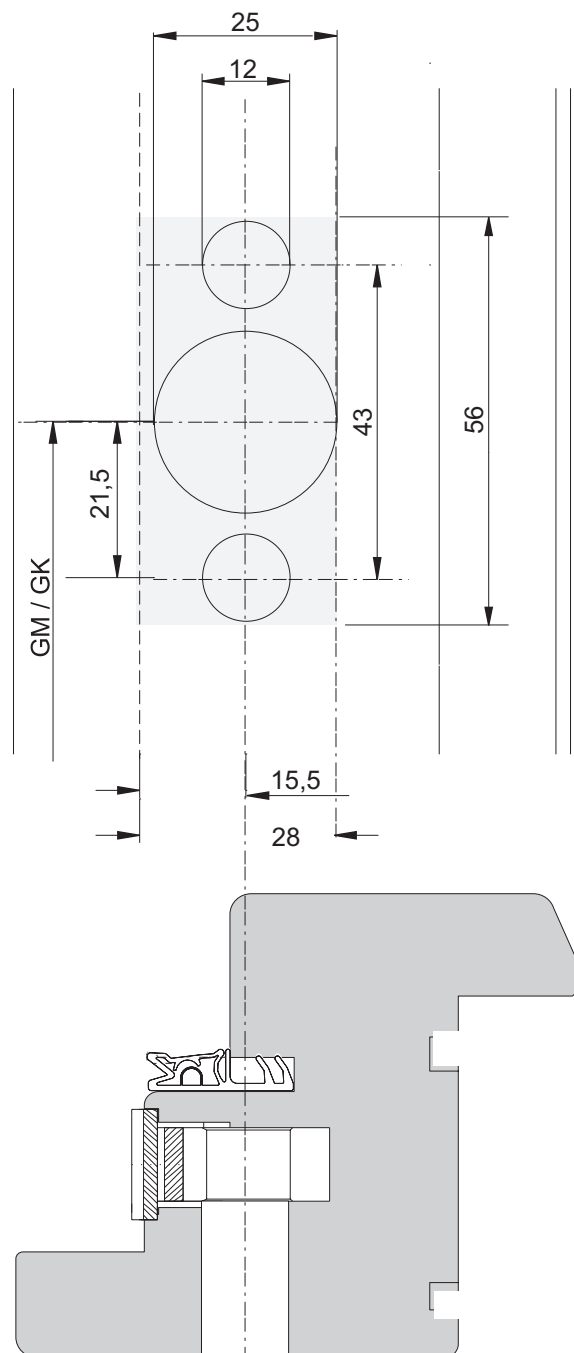

Scale drawing "Gear lock" for backset = 15.5 mm

Table of gap dimensions for windows that are flush or offset on the inside

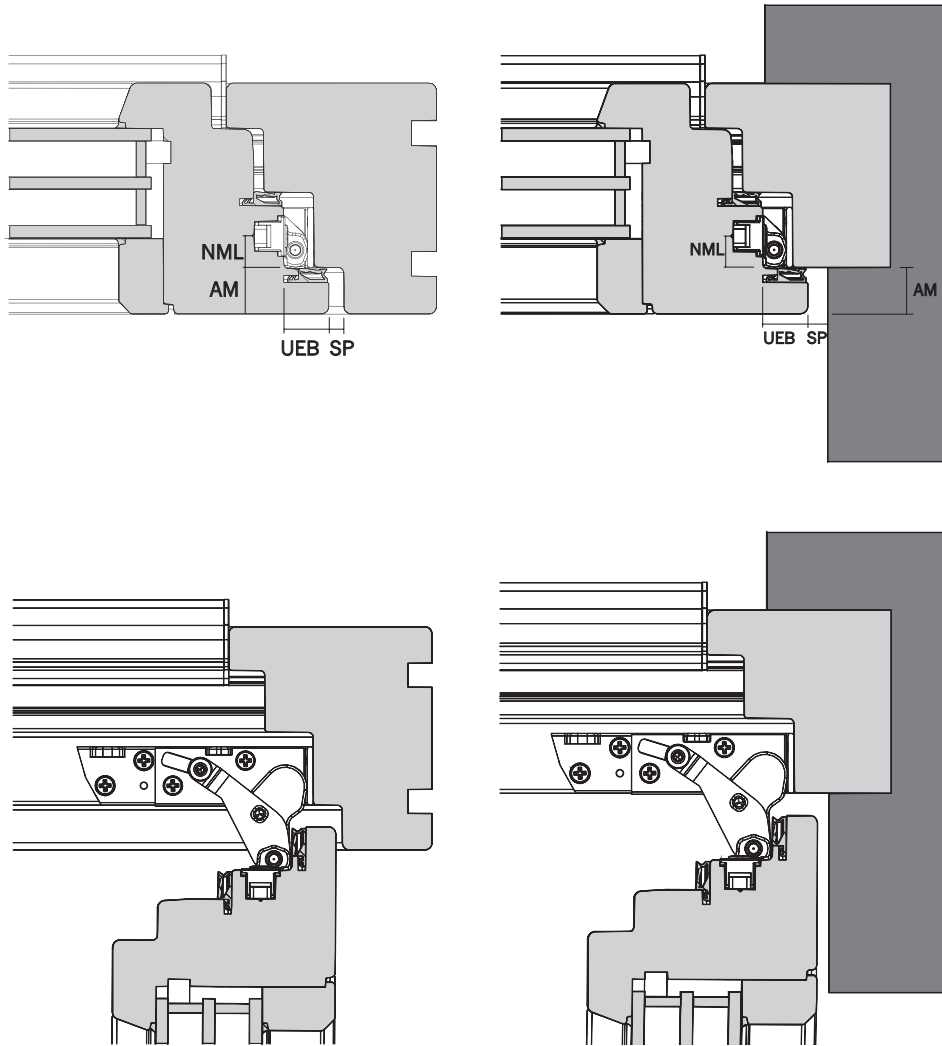

AM	UEB	SP 13 mm NML	SP 9 mm NML
10	20	4	4
16	20	4	6
18	20	6	8
20	20	8	10
22	20	10	12
10	18	4	5
16	18	6	8
18	18	8	10
20	18	10	12
22	18	12	14

AM = overlap dimension
 UEB = overlap
 NML = groove centre position
 SP = Min. gap dimension
 The gap dimensions also depend on the shape and radiuses of the overlap.

See figure: Corner drive E1

- Mounting of interlocking rods:
 - Fit the corner drive (2) into the fitting groove at the top of the sash so that the octagonal bolt is on the top side.
 - Fit the corner drive (1) into the fitting groove at the bottom of the sash so that the octagonal bolt is on the underside.
 - Fix both corner drives (1, 2) on the drive side with a single screw each.
 - Measure the sash rebate height (FFH).

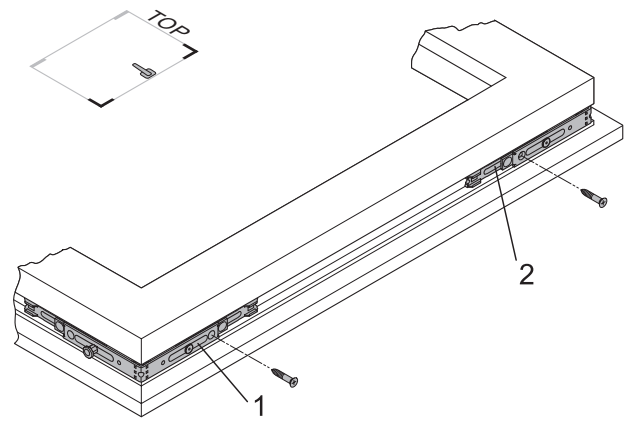

Corner drive E1

See figure: Drive rod GAM/GAK

- Cut the drive rod according to the instructions.
- Mount the drive rod:
 - Abut the drive rod (2) flush against the corner drive (3).
 - Allow the teeth on the drive rod to click into position on the gear rack on the corner drive.
 - Clip the drive rod into the corner drive (1) in the same way.
 - Press the drive rod into the eurogroove.
 - Screw the drive rod from the bottom up.

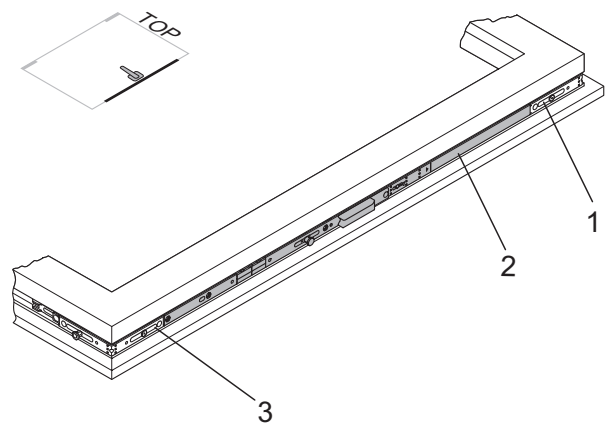

Drive rod GAM/GAK



Note: Please make sure that the installation position of the drive rod is correct!

See figure: Corner Drive E1.SE

- Fit the corner drive (1) into the fitting groove at the top of the sash so that the octagonal bolt is on the hinge side.
 - Fasten the corner drive on the sash using a screw (2).
 - Measure the sash rebate width (FFB).
-
- Cut the top rod (see chapter 'Shortening the fittings').

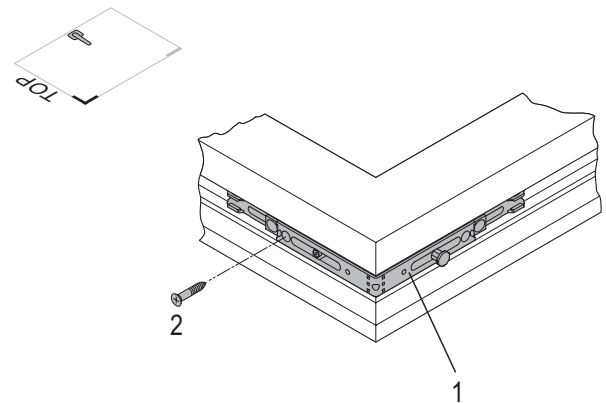

Corner Drive E1.SE

See figure: Top Rod OS.SE

- Insert the top rod and screw into position.
- Fit the top rod flush against the corner drive (1).
- Allow the gear teeth to click into place on the rack in the corner drive.
- Clip the top rod into the corner drive (3) in the same way.
- Press the top rod into the fitting groove.
- Screw the top rod from the hinge side to the drive side.

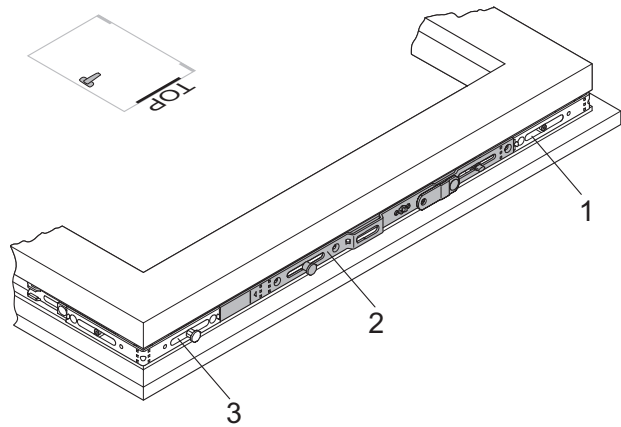

Top Rod OS.SE



Note: For FFH < approx. 600 mm (depending on profile), place tilt limiter on top rod OS... (2).

See figure: Interlocking rod M/MK (hinge side)

- Install Interlocking Rod on the hinge side.
- Fit the interlocking rod (1) flush against the corner drive (2).
- Click the interlocking rod gears into the teeth of the corner drive.
- Press the interlocking rod into the fitting groove.
- Screw the interlocking rod from the top down.
- Tighten the screw (3) fully to release the central fastening.

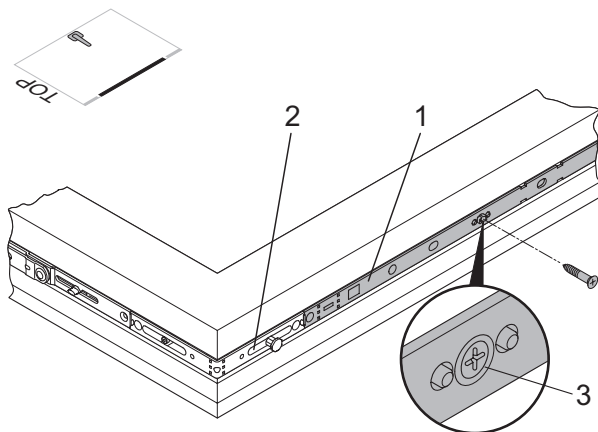

Interlocking rod M/MK (hinge side)



Note: For a sash rebate height (FFH) and/or sash rebate width (FFB) of approx 1,000 mm and more, an interlocking rod should also be fitted hinge-side and/or horizontally at the base. (Observe distance between locking points according to CE certification)



Please note! Damage to fittings. If the central fastening is not released, the locking device cannot be actuated. Use of force will lead to torsion of the fittings. Always insert the screw fully up to the stop.

See figure: Corner drive E1

- Screw the corner drive (1) in place.

i Note: the following step is not needed, if you do not fit centre locking to the top corner drive.

See figure: Interlocking rod M/MK (horizontal)

- Mount interlocking rod on the underside:
 - Fit the interlocking rod (2) flush against the corner drive (1).
 - Click the interlocking rod gears into the teeth of the corner drive.
 - Press the interlocking rod into the fitting groove.
 - Screw the interlocking rod from the corner drive to the centre of the window.
 - Tighten the screw (3) fully to release the central fastening.

! Please note! Damage to fittings. If the central fastening is not released, the locking device cannot be actuated. Use of force will lead to torsion of the fittings. Always insert the screw fully up to the stop.

See figure: Sash Hinge FL.IF

- Insert the sash hinge (1) into the fitting groove on the bottom of the sash.
- Make sure the sash hinge is fitted correctly into position.
- Screw the sash hinge (1) in place (start at hinge side).

i Note: If a turn limiter is to be connected to the sash hinge, the screw hole (2) must be exposed first.

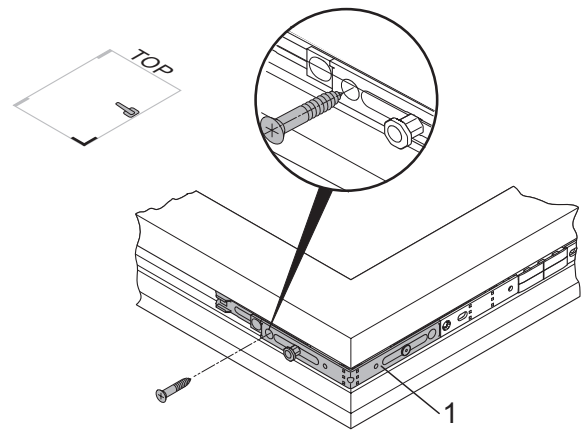

Corner drive E1

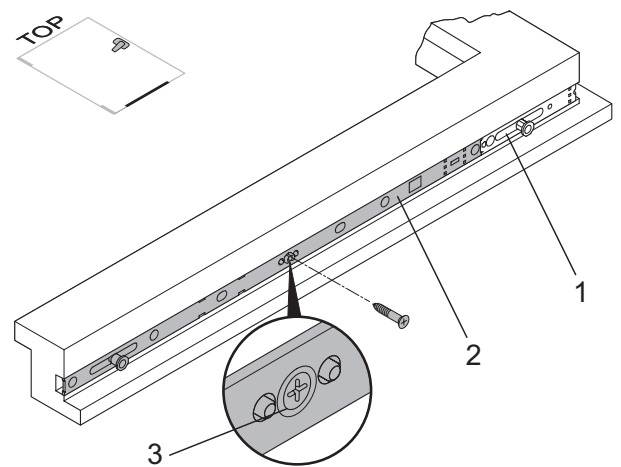

Interlocking rod M/MK (horizontal)

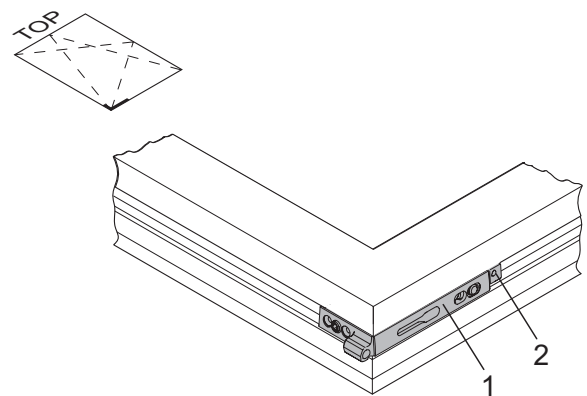

Sash Hinge FL.IF

See figure: Turn Limiter DB.IF

- Install turn limiter
 - Insert the turn limiter (2) into the fitting groove and connect to the sash hinge (1).
 - Fasten the turn limiter (2) tightly to the sash hinge (1) with a screw.
 - Push the shear arm down so that the screw holes underneath are exposed.
 - Screw turn limiter (2) into place.



Note: The holder (3) must point downwards with the guide edge facing the sash overlap.

Using the turn limiter is imperative if:

- Reveal depth of surrounding masonry < 120 mm (DIN EN 13126-8, Point 4)



Note: A turn limiter should optionally be used on elements that are used as a doorway.



Please note! Check if all screws are fixed into place on the fitting parts.

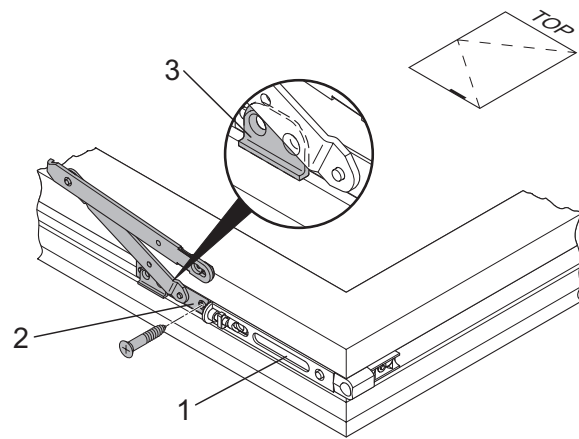

Turn Limiter DB.IF

Mounting of fittings on sash

Turn double sash type – Rectangular window

i Note: The following figures refer to a window for left hand use. When fitting a window for right-hand use, the figures will be mirror-inverted.

See figure: Corner drive E1

- Mounting of interlocking rods:
 - Fit the corner drive (2) into the fitting groove at the top of the sash so that the octagonal bolt is on the top side.
 - Fit the corner drive (1) into the fitting groove at the bottom of the sash so that the octagonal bolt is on the underside.
 - Fix both corner drives (1, 2) on the drive side with a single screw each.
 - Measure the sash rebate height (FFH).

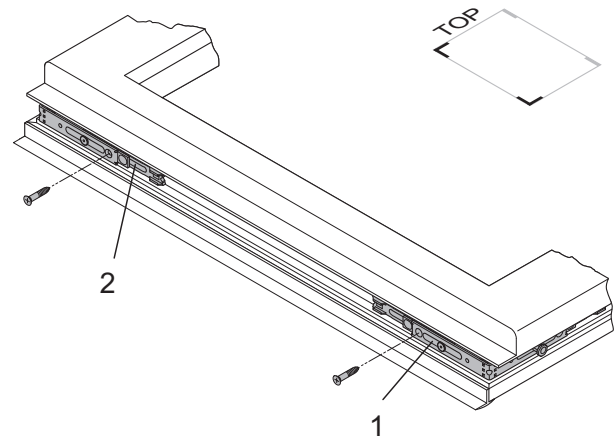

Corner drives E1

- Shorten the drive rod:
 - Shorten drive rod GASM or drive rod GASK in line with description "Shortening the fittings".

i Note: Make sure you shorten the drive rod in closed state (as delivered).

See figure: Drive rod GASM/GASK

- Mount the drive rod:
 - Abut the drive rod (2) flush against the corner drive (3).
 - Allow the teeth on the drive rod to click into position on the gear rack on the corner drive.
 - Clip the drive rod into the corner drive (1) in the same way.
 - Press the drive rod into the eurogroove.
 - Screw the drive rod from the bottom up.

i Note: to keep a neutral position, do not perform a function test until all fittings are in place.

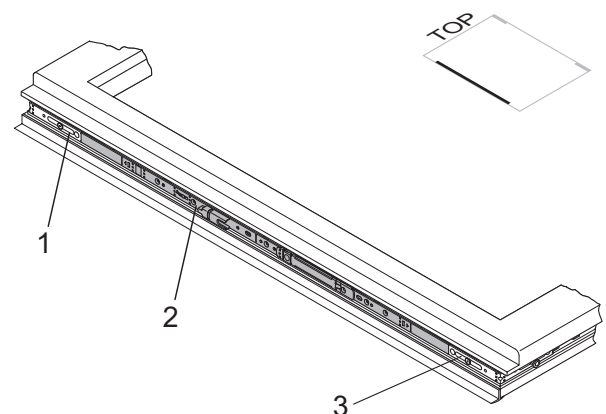

Drive rod GASM/GASK

See figure: Turn hinge rail DLS.IF

- Install turn hinge rail:
- Insert turn hinge rail (1) into the fitting groove on the top of the sash.
- Make sure the turn hinge rail is fitted correctly into position on the hinge side.
- Screw top hinge rail tightly onto the sash.

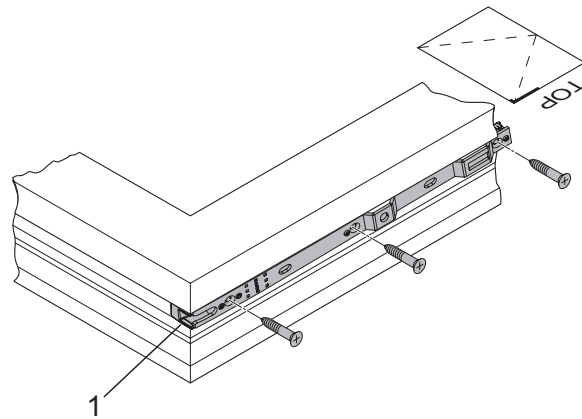

Turn hinge rail DLS.IF

See figure: Interlocking rod M (top)

- Mount the interlocking rod on the top side:
- Fit the interlocking rod (1) flush against the corner drive (2).
- Click the interlocking rod gears into the teeth of the corner drive.
- Press the interlocking rod into the fitting groove.
- Screw the interlocking rod tight from the hinge side to the gear side.
- Tighten the screw (3) fully to release the central fastening.

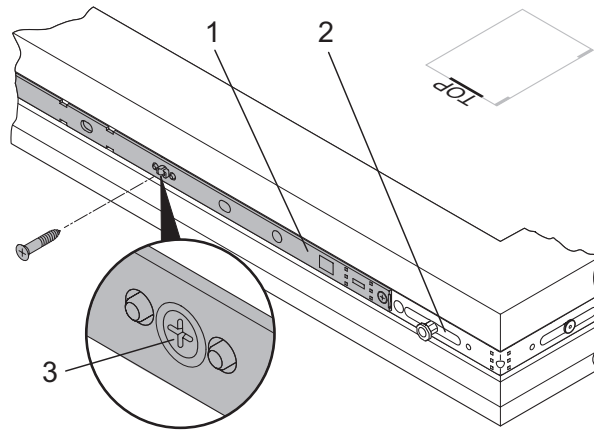

Interlocking rod M (top)



Please note! Damage to fittings. If the central fastening is not released, the locking device cannot be actuated. Use of force will lead to torsion of the fittings. Always insert the screw fully up to the stop.

See figure: Interlocking rod M (bottom)

- Mount interlocking rod on the underside:
- See above

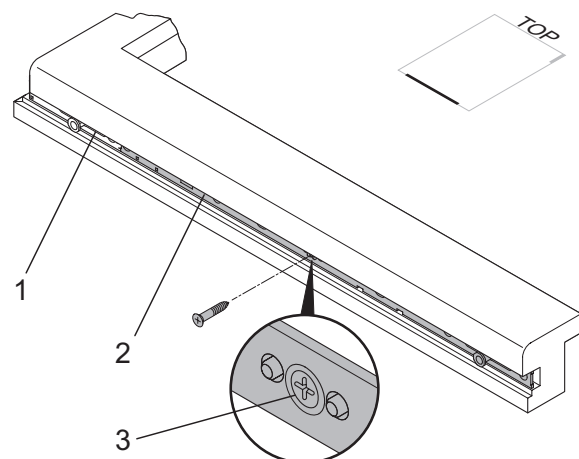

Interlocking rod M (bottom)

See figure: Claw bolt ZV-FT (hinge side)

- Position the claw bolt (1):
- S (ZV-FT) = sash rebate edge to centre of keep ZV-FT
- Press the claw bolt into the eurogroove and screw in place.

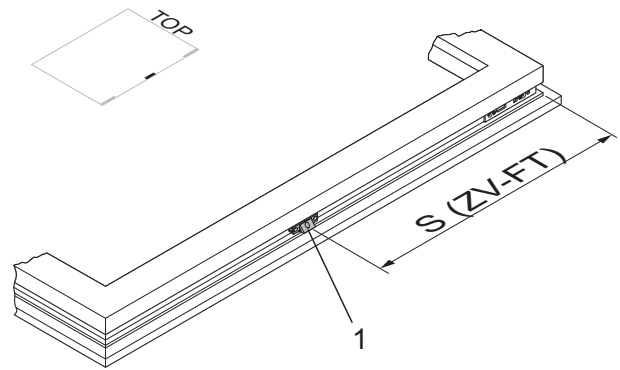

Claw bolt ZV-FT (hinge side)

See figure: Sash Hinge FL.IF

- Fitting the sash hinge:
- Insert the sash hinge (1) into the fitting groove on the bottom of the sash.
- Make sure the sash hinge is fitted correctly into position.
- Screw the sash hinge (1) in place (start at hinge side).

i Note: If a turn limiter is to be connected to the sash hinge, the screw hole (2) must be exposed first.

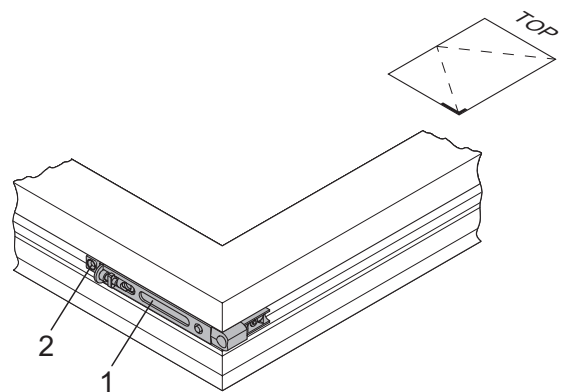

Sash Hinge FL.IF

See figure: Turn Limiter DB.IF

- Install turn limiter
- Insert the turn limiter (2) into the fitting groove and connect to the sash hinge (1).
- Fasten the turn limiter (2) tightly to the sash hinge (1) with a screw.
- Push the shear arm down so that the screw holes underneath are exposed.
- Screw turn limiter (2) into place.

i Note: The holder (3) must point downwards with the guide edge facing the sash overlap.

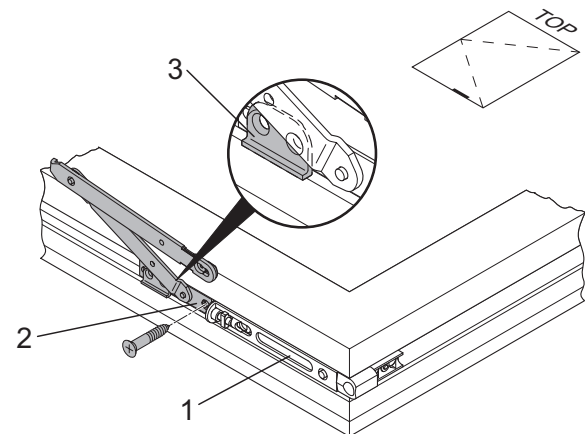

Turn Limiter DB.IF

Using the turn limiter is imperative if:

- Reveal depth of surrounding masonry < 120 mm (DIN EN 13126-8, Point 4)

i Note: A turn limiter should optionally be used on elements that are used as a doorway.

Mounting of fittings on the window frame

Turn-tilt type – Rectangular window

Keep positions

The following figures show the keep position options. The number of keeps depends on the size of the window. It is only possible to use frame parts which are suitable for the profile systems concerned and which have been approved by Winkhaus. The use of frame parts not developed especially for the frame profile concerned is not permitted and excludes us from any liability.



Note: The dimensions in the illustrations refer to the length from the frame rebate edge to the keep profile edge! A quick and simple assembly is made possible with the help of mounting jigs.

Turn-tilt type

GAK

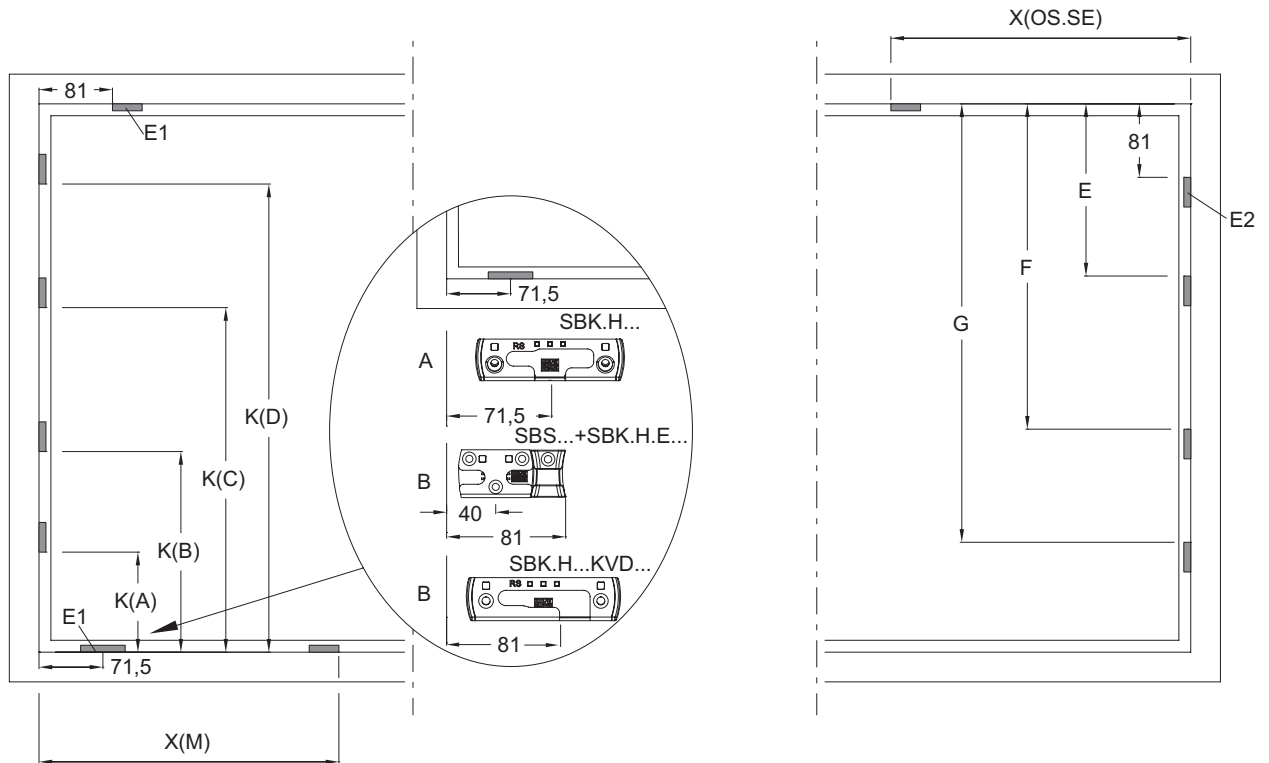
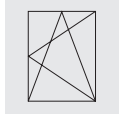

13

GAK...	K(A) [mm]	K(B) [mm]	K(C) [mm]	K(D) [mm]
GAK.830-1	385	-	-	-
GAK.945-1	385	-	-	-
GAK.1100-1	500	-	-	-
GAK.1195-1	750	-	-	-
GAK.1195-2	250	750	-	-
GAK.1325-1	750	-	-	-
GAK.1325-2	385	750	-	-
GAK.1550-1	750	-	-	-
GAK.1550-2	385	1000	-	-
GAK.1775-2	750	1250	-	-
GAK.1775-3	385	750	1250	-
GAK.2000-2	750	1250	-	-
GAK.2000-4	385	750	1250	1500

M...	X(M) [mm]
M.250-1	230
M.500-1	480
M.750-1	730

OS.SE...	X(OS.SE) [mm]
OS.SE.1025-1 / OS.SE.1025-1.E	480
OS.SE.1250-1 / OS.SE.1250-1.E	730

M...	E [mm]	F [mm]	G [mm]
M.250-1	250	-	-
M.500-1	500	-	-
M.750-1	750	-	-
MK.250-1 + M.250-1	250	500	-
MK.500-1 + M.500-1	500	1000	-
MK.750-1 + M.500-1	750	1250	-
MK.750-1 + M.750-1	750	1500	-
MB.1000-2	500	1000	-
MB.1250-2	750	1250	-
MB.1450-2	750	1450	-
MB.1750-3	750	1250	1750

Tab_181109_2

The illustration GAM.../GAK... shows the keep positions for backsets D15.5, D7.5 and D25-50. These positions also apply to GAMA/GAKA drive rods.
 A = Standard operating sequence turn-tilt (OS.SE...)
 B = Operating sequence Tilt-before-Turn (OS.SE...E)

Turn-tilt type

GAM

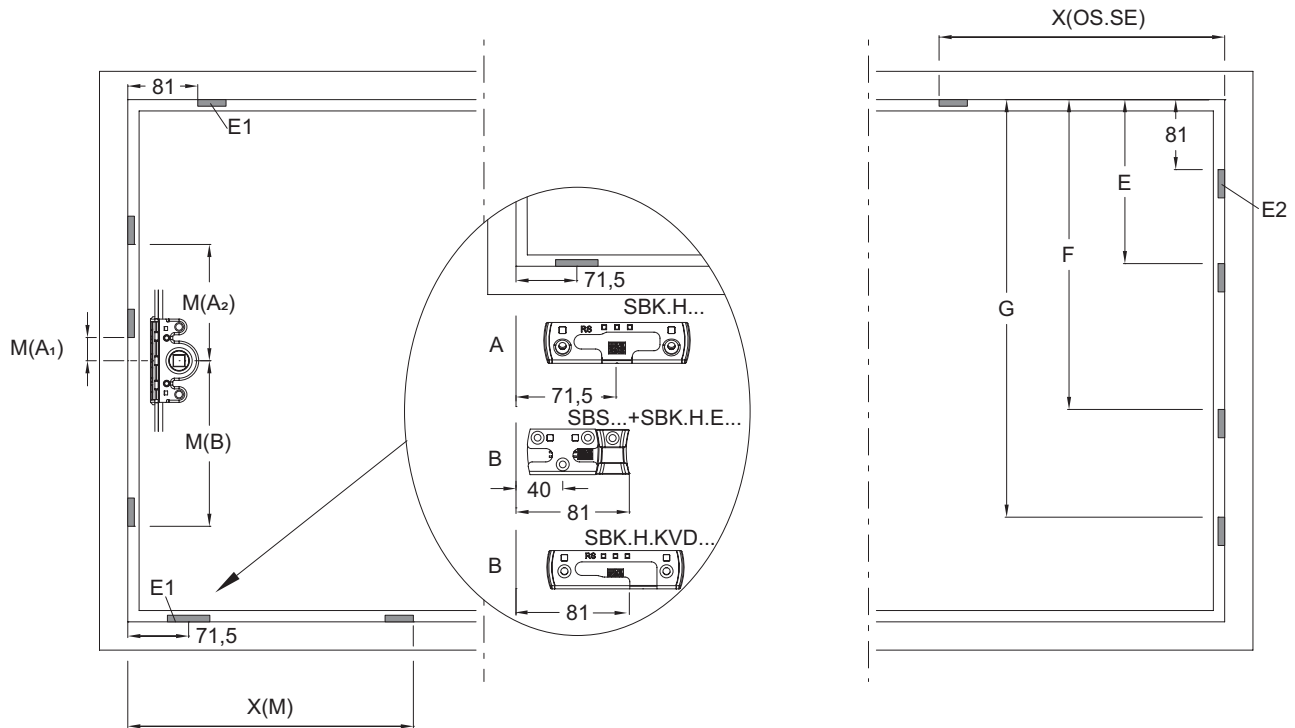
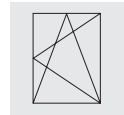

GAM...	M(A ₁) [mm]	M(A ₂) [mm]	M(B) [mm]
GAM.1050-1	127	-	-
GAM.1400-1	127	-	-
GAM.1400-2	127	-	223
GAM.1800-2	-	260	340
GAM.2300-3	127	692	520

M...	X(M) [mm]
M.250-1	230
M.500-1	480
M.750-1	730

OS.SE....	X(OS.SE) [mm]
OS.SE.1025-1 / OS.SE.1025-1.E	480
OS.SE.1250-1 / OS.SE.1250-1.E	730

M...	E [mm]	F [mm]	G [mm]
M.250-1	250	-	-
M.500-1	500	-	-
M.750-1	750	-	-
MK.250-1 + M.250-1	250	500	-
MK.500-1 + M.500-1	500	1000	-
MK.750-1 + M.500-1	750	1250	-
MK.750-1 + M.750-1	750	1500	-
MB.1000-2	500	1000	-
MB.1250-2	750	1250	-
MB.1450-2	750	1450	-
MB.1750-3	750	1250	1750

Tab_181109_1

The illustration GAM.../GAK... shows the keep positions for backsets D15.5, D7.5 and D25-50. These positions also apply to GAMA/GAKA drive rods.
 A = Standard operating sequence turn-tilt (OS.SE...)
 B = Operating sequence Tilt-before-Turn (OS.SE...E)

Turn windows

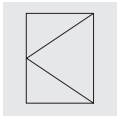

GAVM

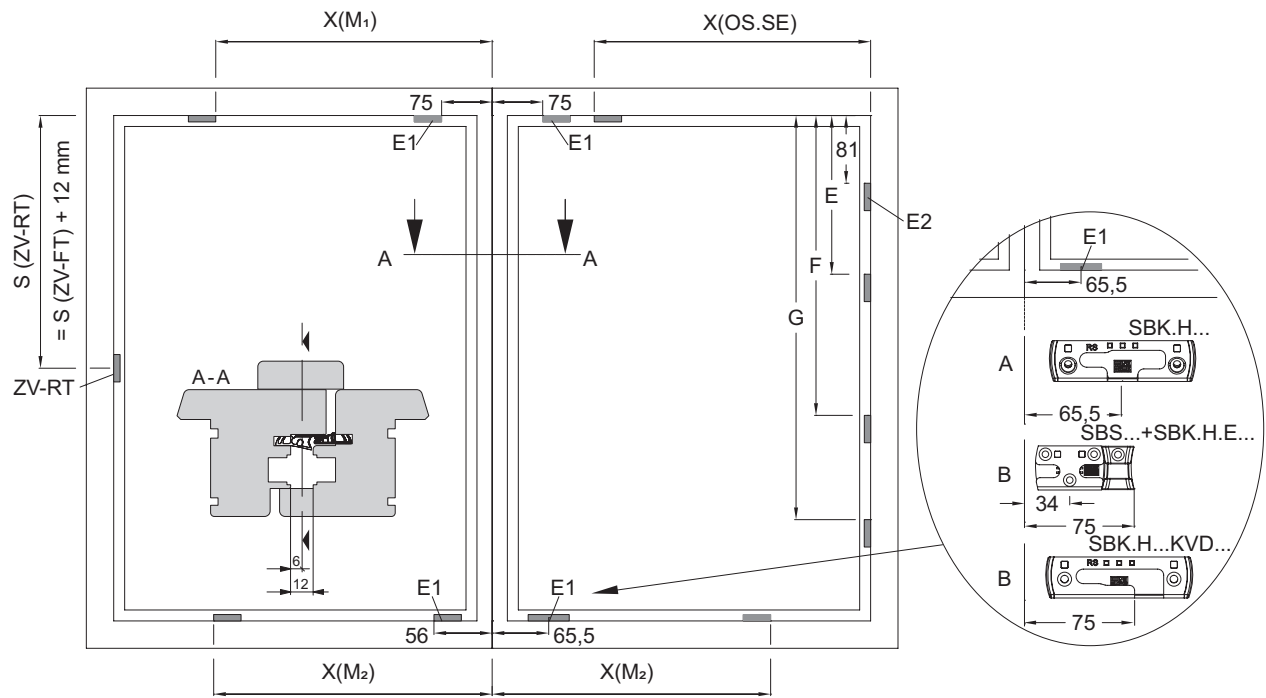

M...	X(M ₁) [mm]
M.250-1	244
M.500-1	494
M.750-1	744

OS.SE...	X(OS.SE) [mm]
OS.SE.1025-1 / OS.SE.1025-1.E	480
OS.SE.1250-1 / OS.SE.1250-1.E	730

M...	X(M ₂) [mm]
M.250-1	224
M.500-1	474
M.750-1	724

M...	E [mm]	F [mm]	G [mm]
M.250-1	250	-	-
M.500-1	500	-	-
M.750-1	750	-	-
MK.250-1 + M.250-1	250	500	-
MK.500-1 + M.500-1	500	1000	-
MK.750-1 + M.500-1	750	1250	-
MK.750-1 + M.750-1	750	1500	-
MB.1000-2	500	1000	-
MB.1250-2	750	1250	-
MB.1450-2	750	1450	-
MB.1750-3	750	1250	1750





Tab_181109_8

The GAVM pictures / tables show the keep positions for backsets D15.5 and D7.5.

Fitting the keeps

Handling of mounting jigs is explained by reference to the LE.N.K. 710-1100 mounting jig in the following. Other mounting jigs are used in the same way. To position keeps, place the mounting jig on the frame rebate edge.

Labelling of mounting jigs

	Horizontal attachment = red element (for top rod and interlocking rod)
	Vertical attachment = yellow element (for drive rods and interlocking rods)
	Vertical / horizontal attachment = blue element (for corner drives)
	= Keep run-in

Keep top horizontal

- Align the mounting jig with the yellow element in the top corner.
- Place the SBA keep on the blue element labelled "E1" and "E2".

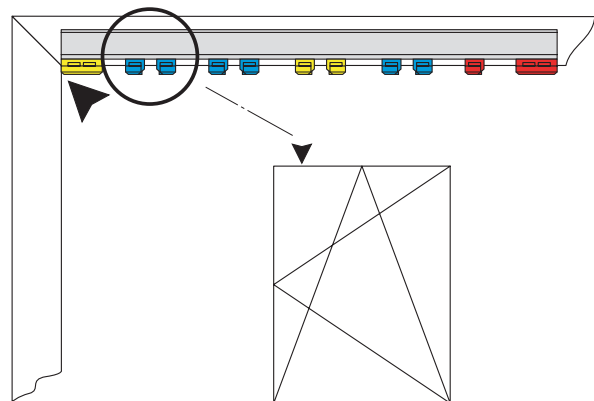

Keep top horizontal

Keep for top rod OS...

- Align the mounting jig with the red element in the top corner.
- Place the keep SBA on the blue element labelled "OS. ...".

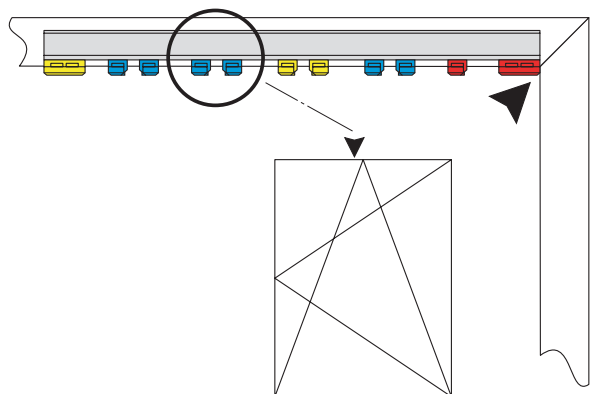

Keep for top rod OS...

Keeps hinge side

- Align the mounting jig with the yellow element in the top corner.
- Position the keep for the corner drive on the blue element.
- Position the keep for interlocking rod on the yellow element.

i Note: The markings on the interlocking rod must match the marking on the yellow element.

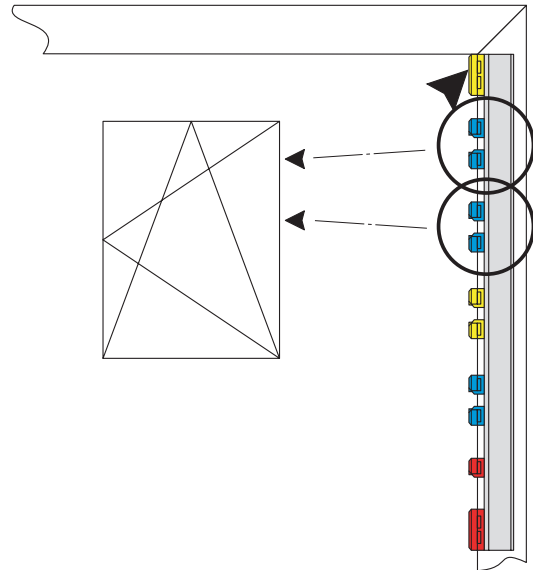

Keeps hinge side

Tilt keep SBK... bottom horizontal

- Align the mounting jig with the red element in the lower corner.
- Place the SBK... keep on the red element marked "Kippblech SBK".

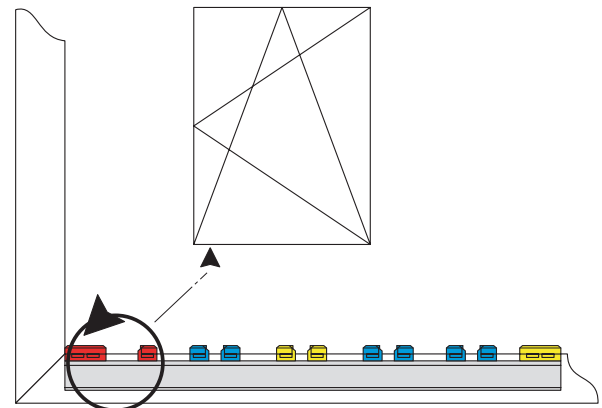

Tilt keep SBK... bottom horizontal

Interlocking Rod M..., bottom, horizontal

See figure: M bottom horizontal

- Align the mounting jig with the red element in the lower corner.
- Position the keep on the blue element marked "M" or "MK".

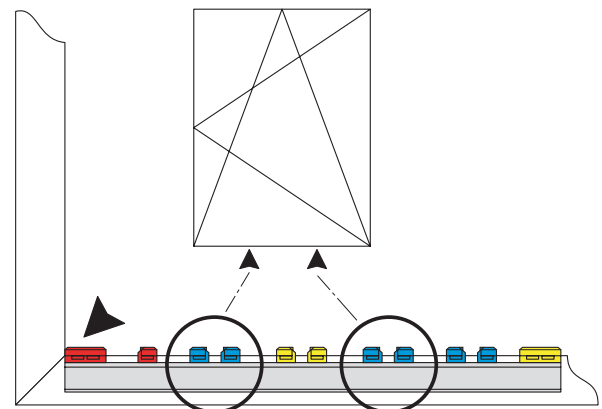

M bottom horizontal

Keeps SBA... for vertical GAK

- Align the mounting jig with the yellow element in the bottom corner.
- Place the SBA. ... keeps on the yellow and blue elements marked "GAK. ...".

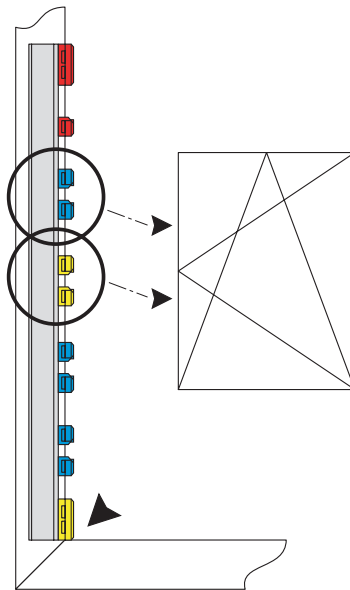

SBA... for vertical GAK

Keeps for GAM

- Attach the corresponding mounting jig labelled "top" or "bottom".
- Fit keeps in line with the labelling on the mounting template.

There are three telescopic jigs depending on the window height:

- LE.N.T. 0710-1050 for drive rod GAM 1050-1
- LE.N.T. 1051-1800 for drive rod GAM 1400-1/2 / 1800-2
- LE.N.T. 1801-2300 for drive rod GAM 2300-3

i Note: The labelling on the drive rod must match the labelling on the yellow templates.

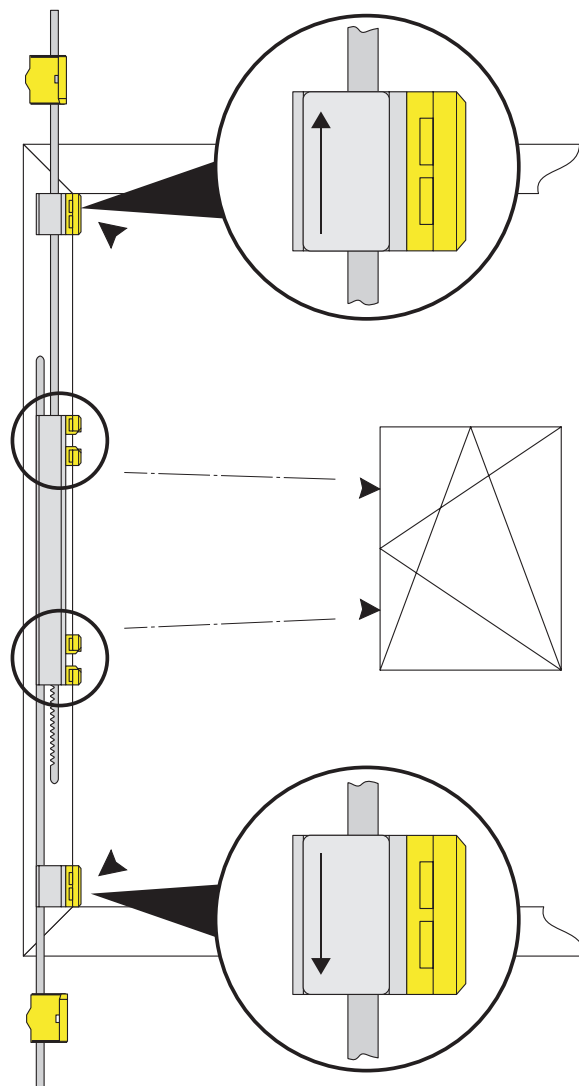

Keeps for GAM

Mounting of fittings on the window frame



It is only possible to use frame parts which are suitable for the profile systems concerned and which have been approved by Winkhaus. The use of frame parts not developed especially for the frame profile concerned is not permitted and excludes us from any liability. Please read the notes on the maximum sash weight in Group 1 (General Product Information).

Note regarding screw fixing

If activPilot Topstar corner and shear hinges are used in timber profiles with low bulk densities ($< 450 \text{ kg/m}^3$) special screws must be used in order to ensure the fitting parts are firmly seated in the frame. The dimensioning of the shaft and head of the screw should correspond to the adjacent figure. If activPilot Topstar corner and shear hinges are used in timber profiles with medium to high bulk densities ($\geq 450 \text{ kg/m}^3$) special screws must be used from a sash weight of 100 kg in order to ensure the hinge parts are firmly seated in the frame. The dimensioning of the shaft and head of the screw should correspond to the adjacent figure. Suitable screws are freely available in retail stores and are not offered by Winkhaus. When selecting the screws, please make sure to observe the TBDK guidelines.

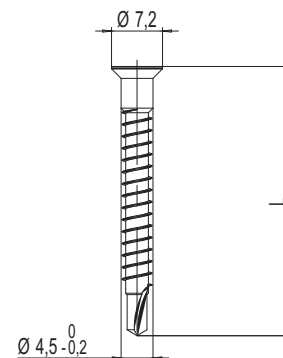

Link: <http://www.beschlagindustrie.de/ggsb/richtlinien.asp>

13

- Bulk density $< 450 \text{ kg/m}^2$ => special screws are stipulated
- Bulk density $\geq 450 \text{ kg/m}^3$ => special screws stipulated from a sash weight of 100 kg

See figure: Corner hinge EL...IF-N

- Mounting the corner hinge
 - Insert the corner hinge (1) into the frame profile.
 - Make sure the corner hinge is fitted correctly into position.
 - Drill screw holes and use suitable screws.
 - Screw corner hinge fully into position.

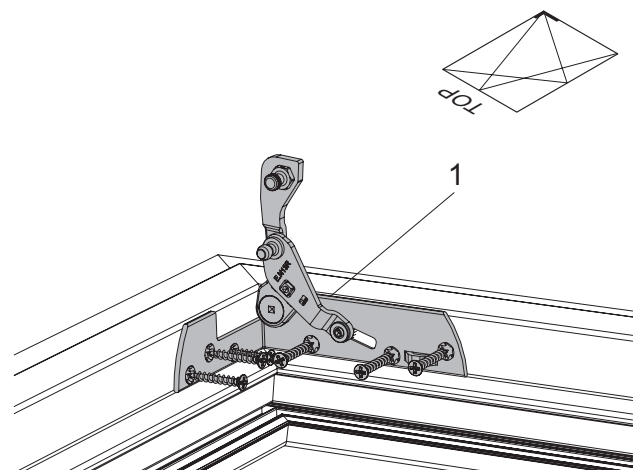

Corner hinge EL...IF-N

See figure: Shear S...IF-N

- Mounting the shear:
 - Insert the shear (1) into the frame profile.
 - Make sure the shear is fitted correctly into position.
 - Drill screw holes and use suitable screws.
 - Screw shear fully into position.

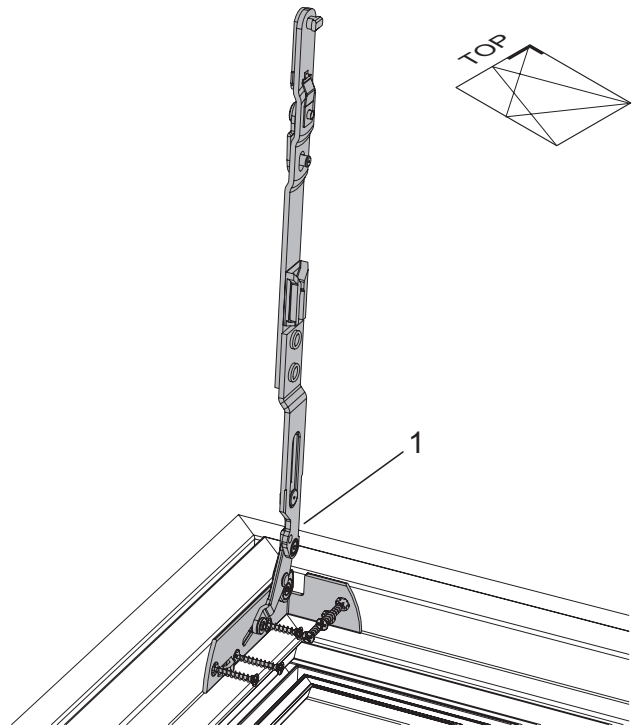

Shear SH...IF-N

See figure: Frame connection RA.DB...IF

- Insert the frame connection (1) into the frame profile and push against the corner hinge.
- Make sure the frame connection is positively locked.
- Drill screw holes and use suitable screws.
- Screw frame connection into place.

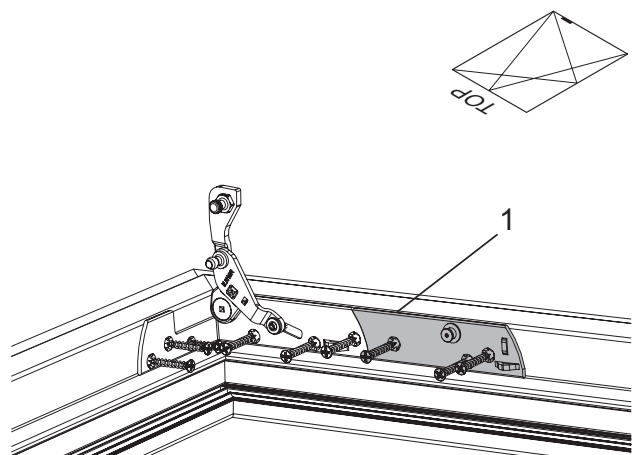

Frame connection RA.DB...IF



Only mount the frame connection if the turn limiter is used.

Fitting the sash

Installing sash at the bottom

See figure: Corner and sash hinges

- Adjust the fitting to "Turn" position.
- (If there is a fail-safe device, disconnect it.)
- Adjust the corner hinge brackets (1) to the "closed" position.
- Pivot the mount securing device (see figure "Installing the sash at the top"; position 1) 90° outwards and pivot the shear into the frame rebate.
- Lower the sash in a slightly tilted position to the brackets (1).
- Insert bolt (2) in the sash hinge top hinge point while inserting the bolt (3) in the sash hinge groove at the same time.



If a turn limiter is used, it must be ensured that it is pivoted inward before the sash is attached. In doing so, damage to the window frame can be avoided!

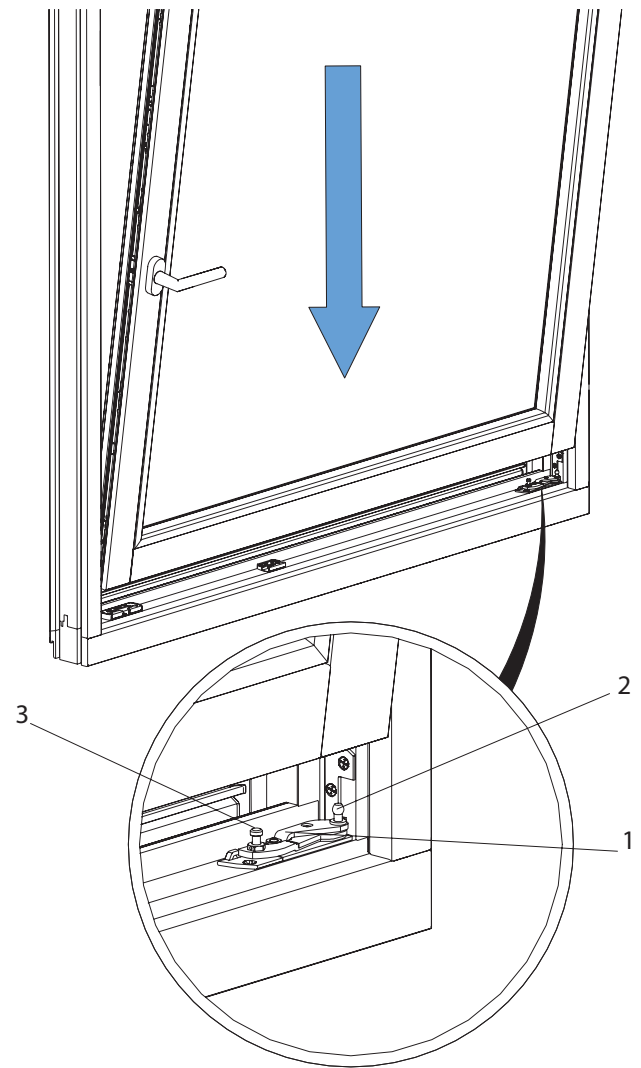

Corner and sash hinges

13

Support the sash!



Open the sash to a 90° turn position and support!



Important: Secure the window sash against falling. Take the heavy sash weight into account! Two people should carry the sash if necessary.

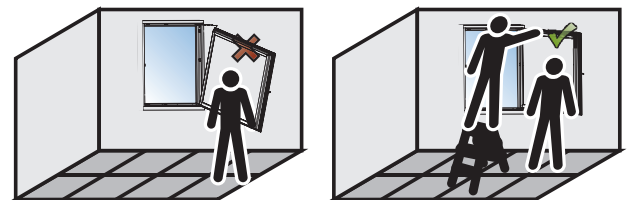

Support the sash!

Engaging the sash at the top

See figure: Engaging the sash at the top

- Open the sash (only surface-mounted on the bottom frame hinge) to a 90° turn position.
- (If there is a fail-safe device, disconnect it.)
- Turn the window handle to the tilt position.
- Open shear 90° and place over the retaining bolt (4) on the top rod.
- Press in the shear bolt (3) into the opening in the counter bracket.
- Press the hammer head bolt into the elongated hole on the top rod. The shear arm should be flush with the top rod.
- Swivel the mount securing device (1) into position by hand, so that the stop spring (2) clicks into place.
- Set fitting to "Turn" position. Then check whether the shear is securely fastened to the top rod and the sash hinge to the corner hinge.



Please note! Risk of injury. The sash can fall out and cause injuries if the shear and top rod are not securely fastened. It is important to ensure the stop spring is firmly in position (clicking sound).



The mount securing device (1) must be pivoted by hand – without the use of tools, such as a hammer, screwdriver, etc. – such that the safety spring (2) detents.

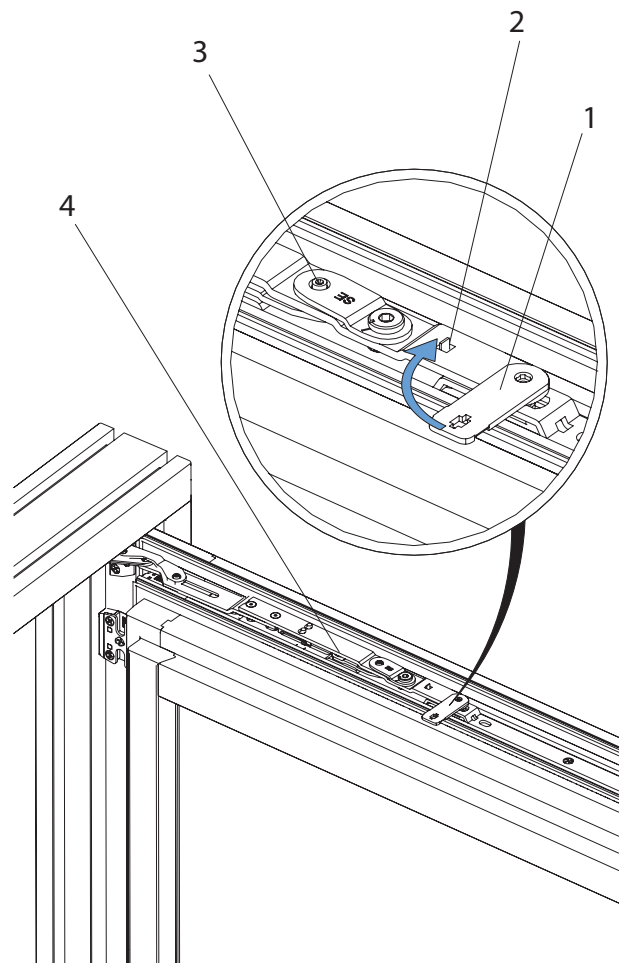

Engaging the sash at the top

Install turn limiter

See figure: Install turn limiter

- Place the turn limiter arm on the retainer pin, so that the stop spring clicks into place behind the retainer pin.
- It is important to ensure the stop spring is firmly in position (clicking sound).

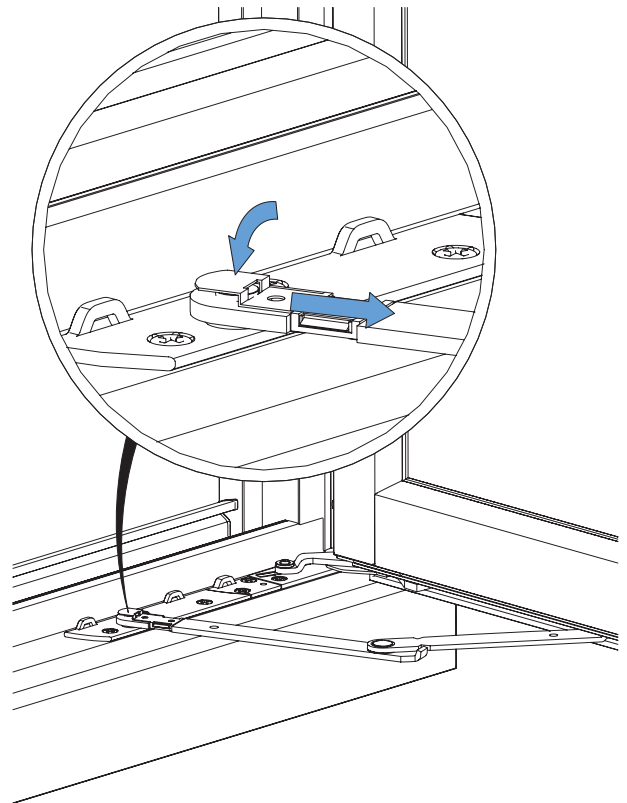

Install turn limiter

Removal of the sash

Detaching the turn limiter

See figure: Detaching the turn limiter

Preparation:

- Move the sash into the 90° turn position.
- Detaching the turn limiter

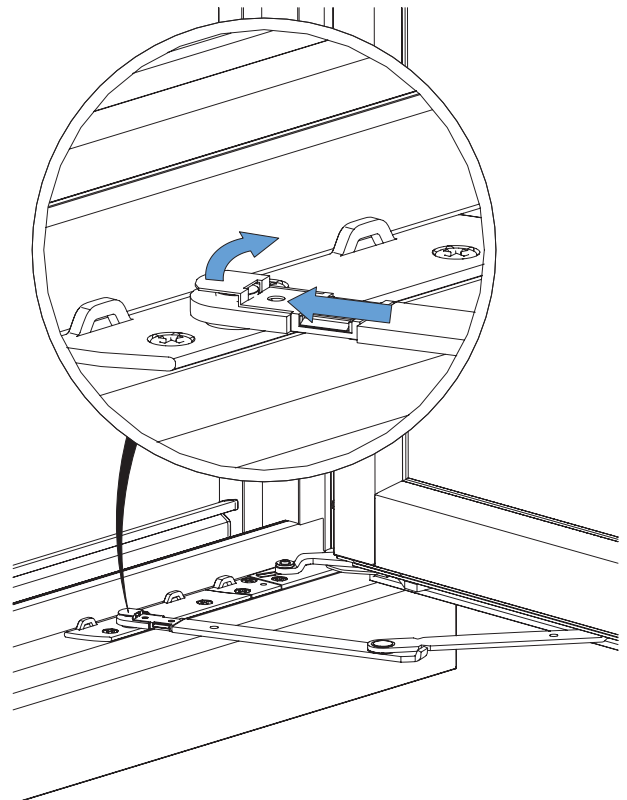

Detaching the turn limiter

Support the sash!

 Open the sash to a 90° turn position and support!

Unlocking the mount securing device

See figure: Remove the sash

Unlocking the mount securing device (1) of the shear:

- Press down the stop spring (2) with a screwdriver while swivelling the mount securing device (1) outwards 90° at the same time.

 Important: Secure the window sash against falling. Take the heavy sash weight into account! Two people should carry the sash if necessary.

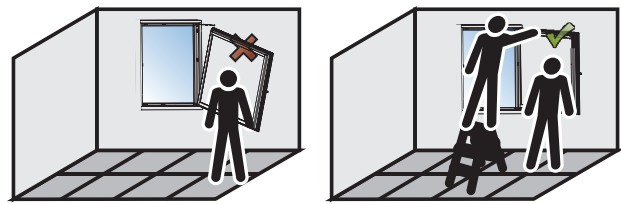

Support the sash!

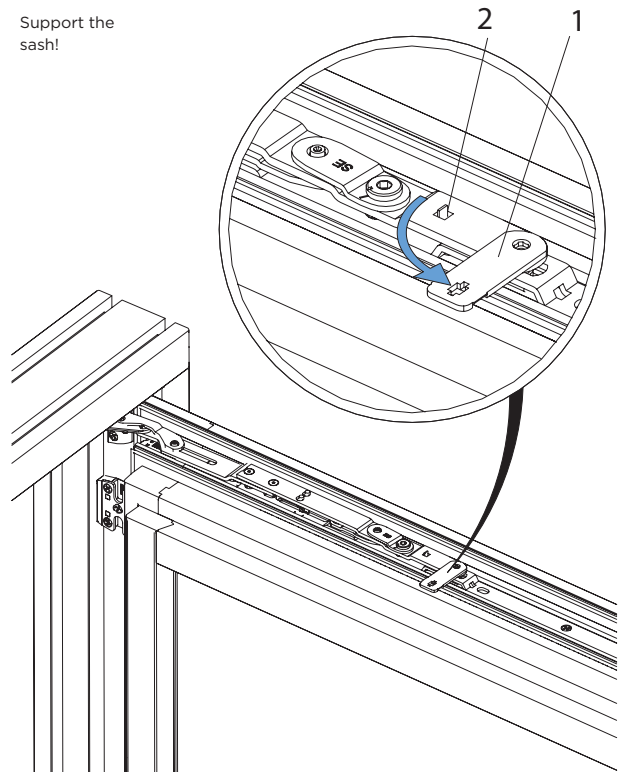

Lifting the sash out of the bottom frame hinge

See figure: Removing the sash

- Pivot the uncoupled shear arm into the frame rebate.
- Move the sash (only surface-mounted on the bottom frame hinge) to a nearly closed position.
- Tilt the sash slightly and lift it up out of the bottom frame hinge.

Remove the sash

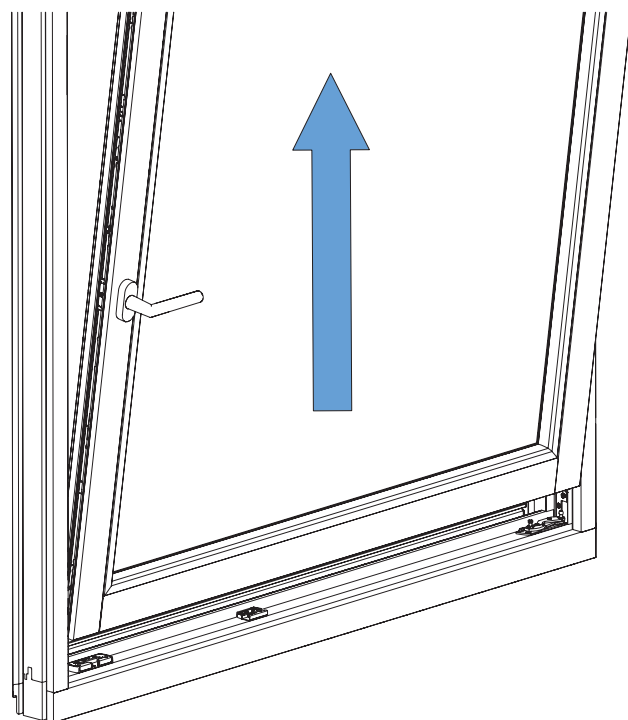

Lifting the sash out of the bottom frame hinge

Function test / Operation

Turn-tilt type

See figure: Function test turn-tilt window

- Place the handle and operate once as follows to release the central fastening.
- Push the handle down (c). The window is closed.
- Move the handle to the central position (a). The window is unlocked; the sash can now be opened fully.
- Close the sash. Push the handle up (b). The window is unlocked; the sash can now be tilted.

i Note: The handle will be stiffer than normal the first time it is used. A clicking noise will be heard during actuation. Keep the window closed during actuation.

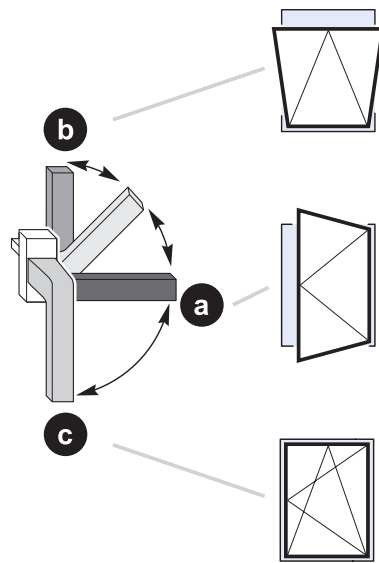

Function test turn-tilt window

Turn double sash type

See figure: Function test turn double sash window

- Actuate the handle as follows to release the central fastening.
- Press the unlocking button (1) and press the lever down to its limit position.
- The window is unlocked; the sash can now be opened fully.

i Note: When you actuate the lever for the first time, the gearing is 'unblocked' and coupling to the connected fittings is established. the handle will be stiffer than normal the first time it is used. A cracking noise can be heard when switching. Keep the window closed during actuation.

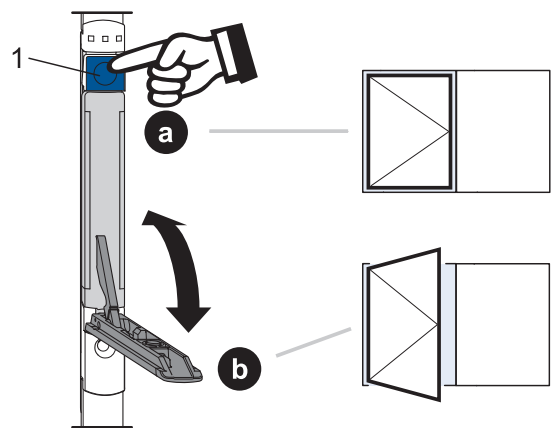

Function test turn double sash window

Adjustment options

Octagonal bolt

Regulate the contact pressure between the sash and the frame (± 0.8 mm) by turning the octagonal bolt. The adjustment can be carried out by means of the Winkhaus adjustment key (V.ST.SCH.HV-11).

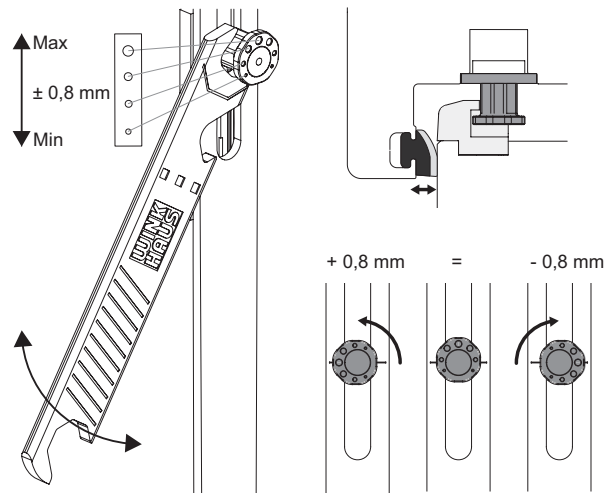

Octagonal bolt

Shears

The sash is raised and lowered by adjusting the shear slide-way. The sash can be raised 2.5 mm and lowered 1.5 mm.

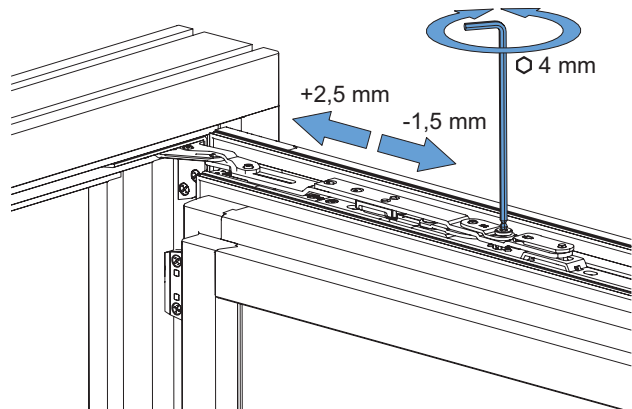

Shears

Adjustment options

Height and side adjustment

Corner and sash hinges

Adjustment tool: Allen key with ball head (size 4)

- Height adjustment +2 mm / 1.5 mm (1)
- Side adjustment +2.5 mm / 2.5 mm (2)

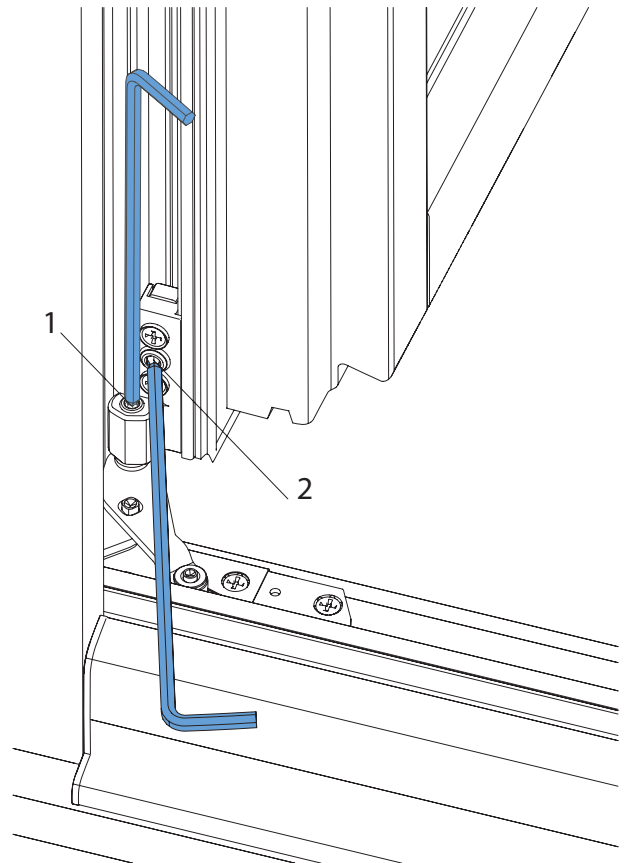

Height and side adjustment

Contact pressure adjustment

Sash hinges

Adjustment tool: Open-ended spanner (size 10)

- Pressure adjustment ± 0.8 mm

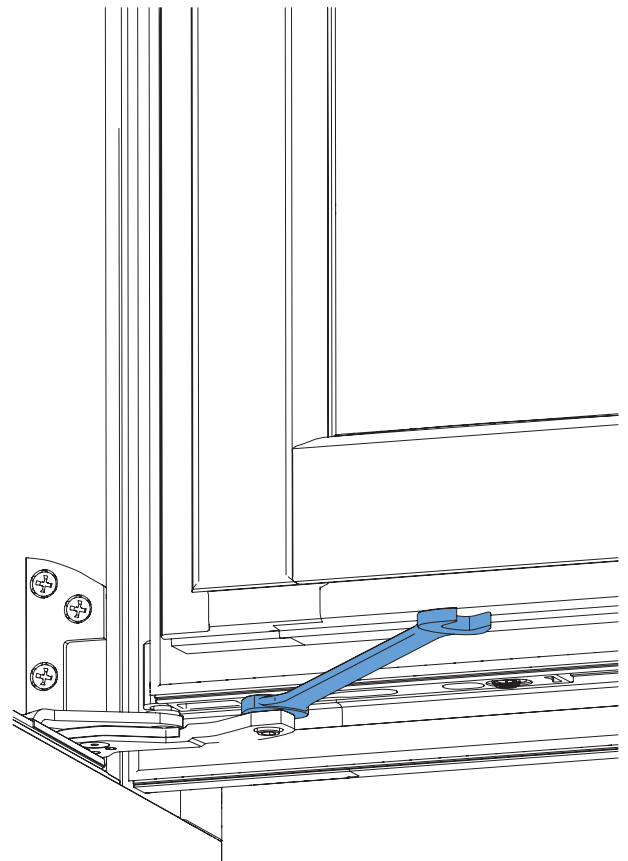

Contact pressure adjustment

Maintenance

Lubrication points

See figure: Overview of lubrication points

The figure shows the location of possible lubrication points which should be lubricated at least once a year.

Positions A, C, D = lubrication points relevant to function.

Position B = safety-relevant lubrication point

i Note: The fitting schematic shown adjacent does not necessarily match the existing fitting. The number of locking positions will vary depending on size and type of the window sash.

! Please note! Risk of injury. The window could fall on removal and thus injure persons. Do not remove the window for maintenance.

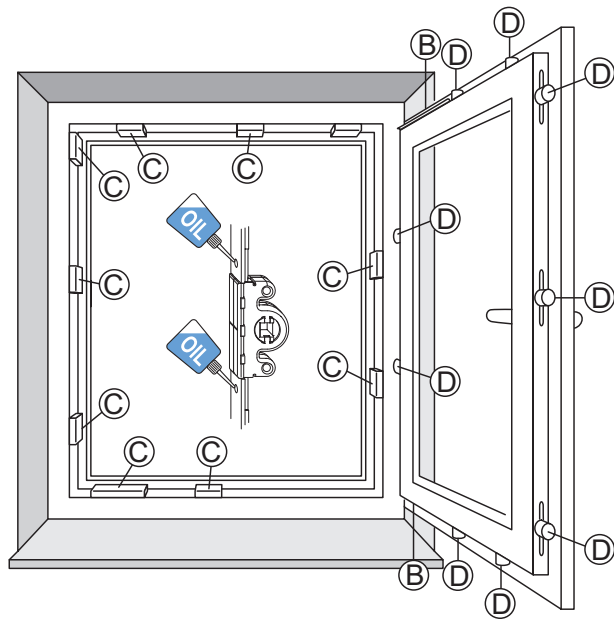

Overview of lubrication points

Locking keeps

See figure: Lubrication points

To keep fittings running smoothly, you must lubricate the keeps at least once a year.

- Lubricate the keeps (C) at the run-in side with technical Vaseline or any other suitable grease.
- Coat the running surfaces of the locking bolts (D) with an oil that is free of resins and acids.

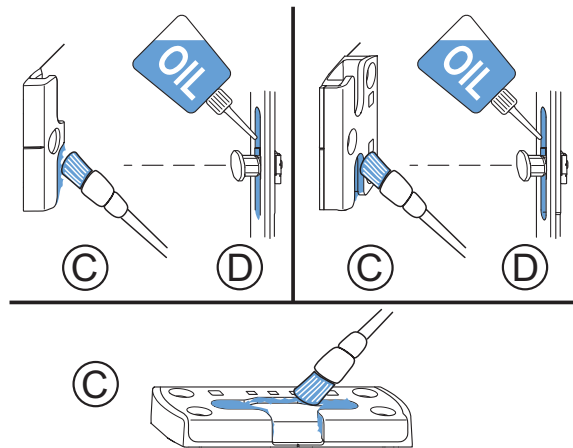

Lubrication points

Ascertaining the run-in sides

See figure: Run-in sides

- Left-handed window; handle right
- Right-handed window; handle left

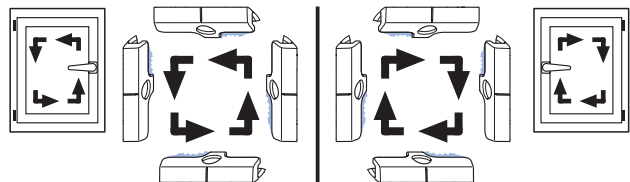

Run-in sides

Maintenance

Lubrication points

Shear and corner hinge

See figure: Shear and corner hinge

Fitting parts are to be tested regularly (at least once annually or semi-annually in schools and hotels) to ensure they are seated firmly and checked for wear. Fastening screws are to be retightened and parts replaced as necessary. Their functionality is to be retested afterwards. All moving contact points on the shear and the corner hinge should be greased with a suitable lubricant at least once a year. Coat lubricating points with non-resinous, non-corroding grease.

B

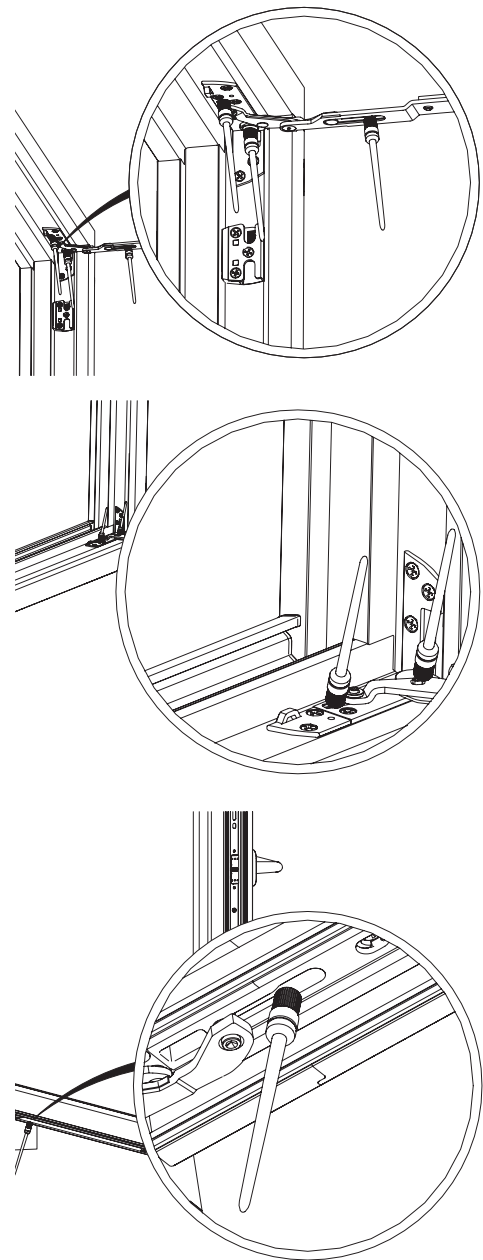
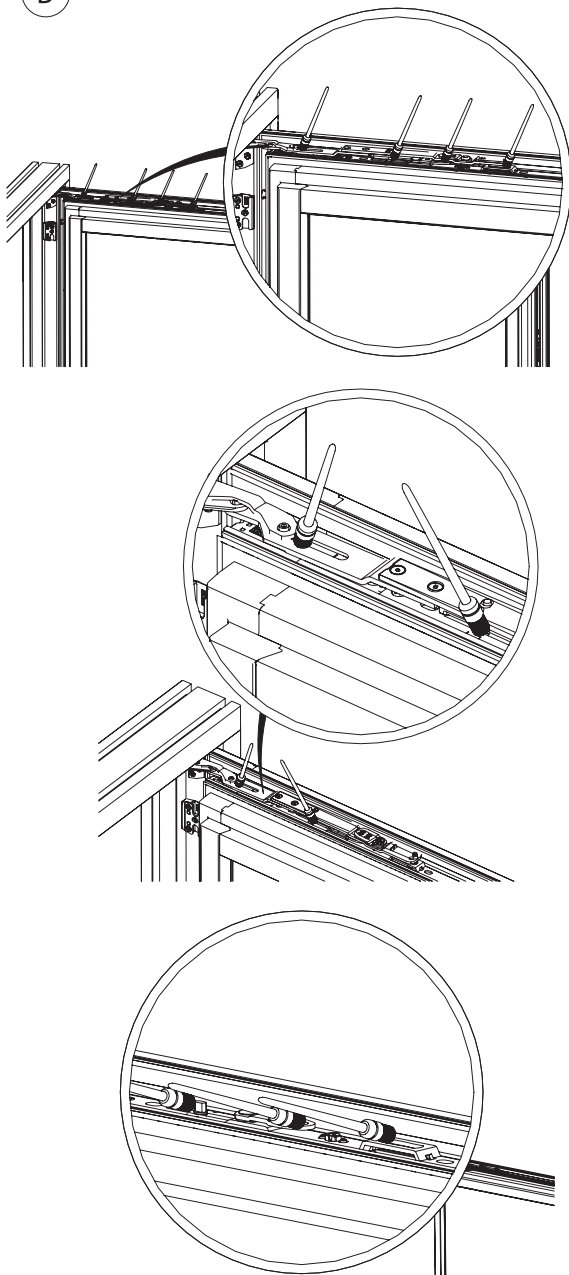

Shear and corner hinge



Please note! Risk of injury. The window could fall on removal and thus injure persons. Do not remove the window for maintenance.

Adjustment and maintenance

Dual/triple function element

DFE/TFE activation

The DFE/TFE element is supplied in the neutral position. Please proceed as follows: Drive in the protruding pin to fix in place (1). Can be used left/right by swivelling out the lever once only. Dribble a few drops of oil (free of resin and acid) onto lubrication points.

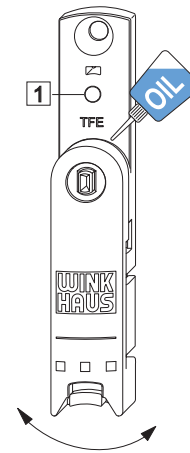

DFE/TFE activation

TFE - Retaining force of balcony door catch

Adjusting the holding force by re-setting the eccentric cam with a 4 mm Allen key. Dribble a few drops of oil (free of resin and acid) onto lubrication points.

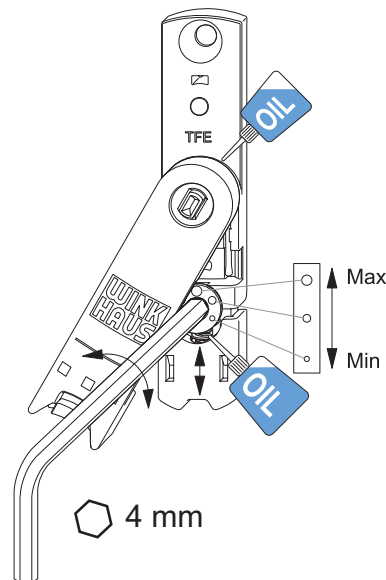

TFE - Retaining force of balcony door catch

Frame part DFE/TFE

Height adjustment (± 3 mm) for sash support plate. Each time fittings are adjusted, the DFE/TFE height setting should also be checked using a 2.5 mm Allen key.

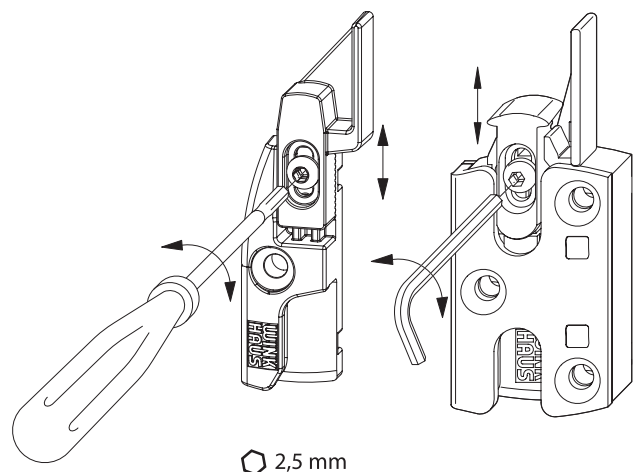

Frame part DFE/TFE

Installation drawings

activPilot Topstar

Corner hinge
shear hinge
turn limiter

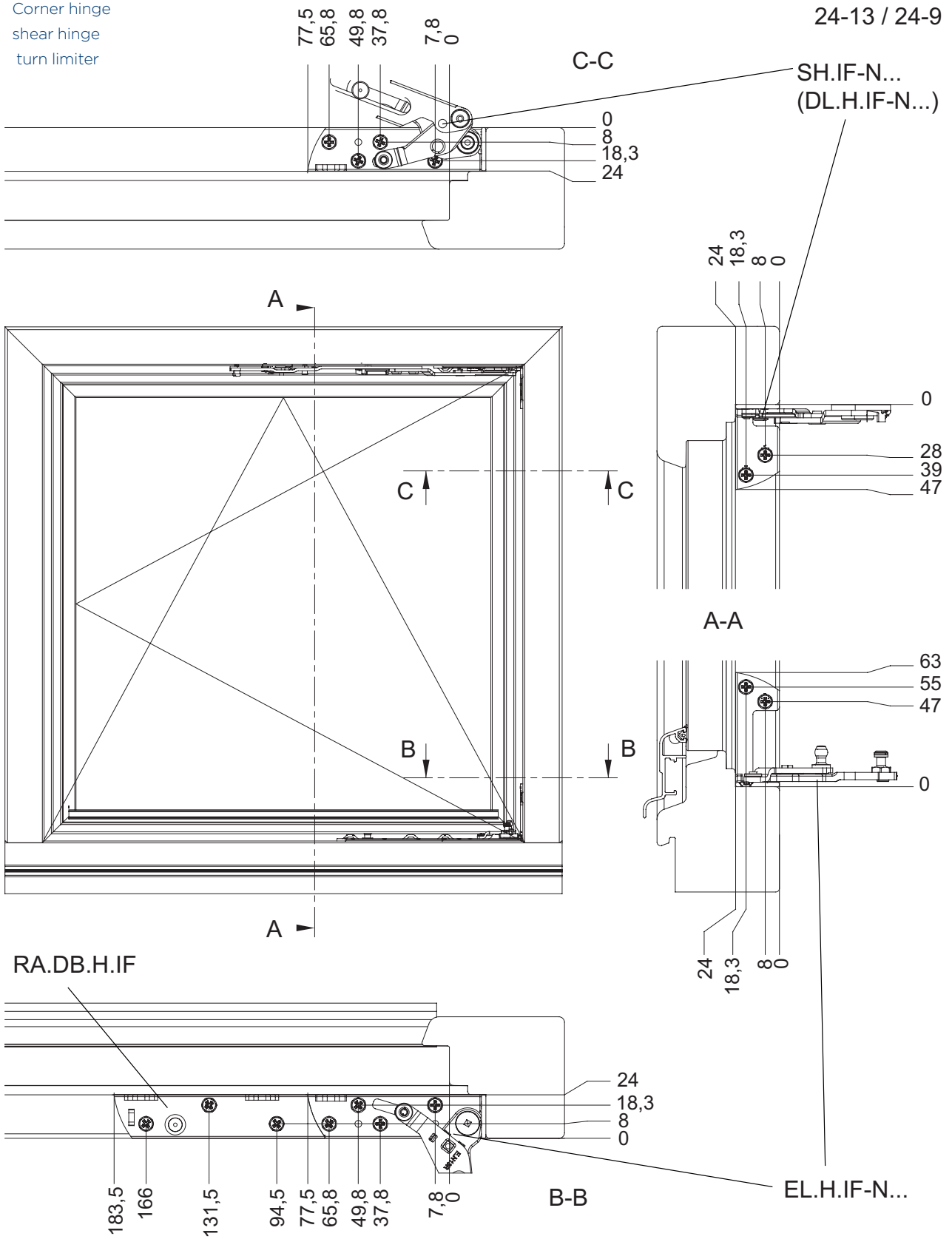

B-6-20: Standard rebate ≥ 24 mm - 9/13 mm NML
Z = positioning pin ($\varnothing 2.5$ mm, length 2 mm)

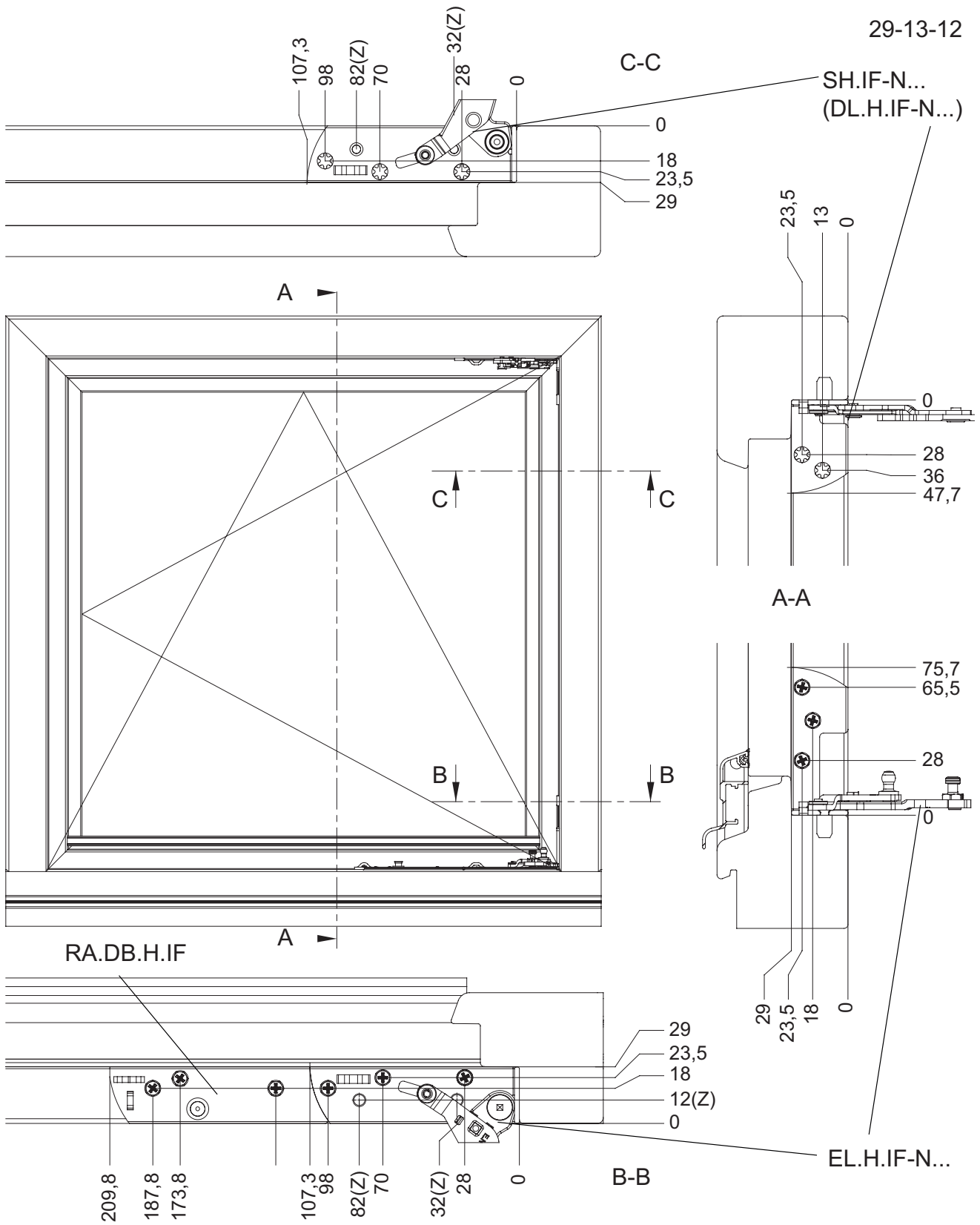

B-6-21: Standard rebate ≥ 29 mm - 13 mm NML
 Z = positioning pins (Ø 8 mm, length 12 mm)

Profile section for groove centre position (NML) of 9/13 mm

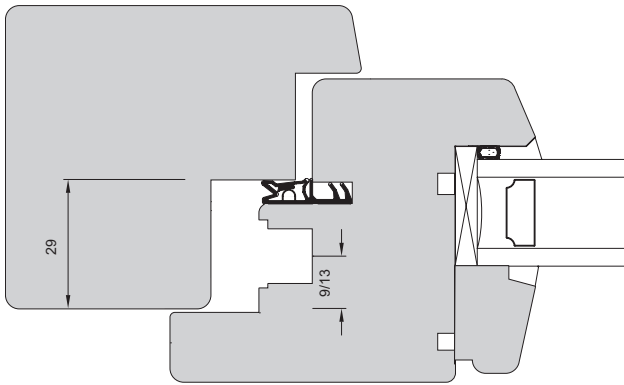

B-11-6: Rebate shape
Standard rebate 29 mm 9/13 mm NML

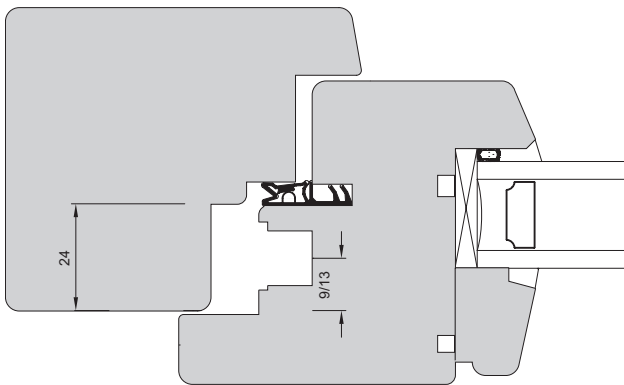

B-11-7: Rebate shape
Standard rebate 24 mm 9/13 mm NML

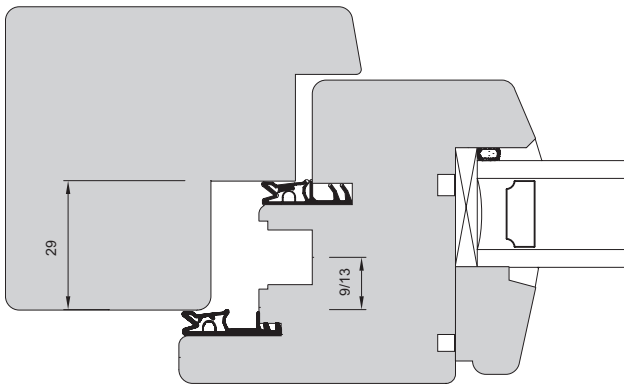

B-11-8: Rebate shape
Standard rebate 29 mm 9/13 mm NML

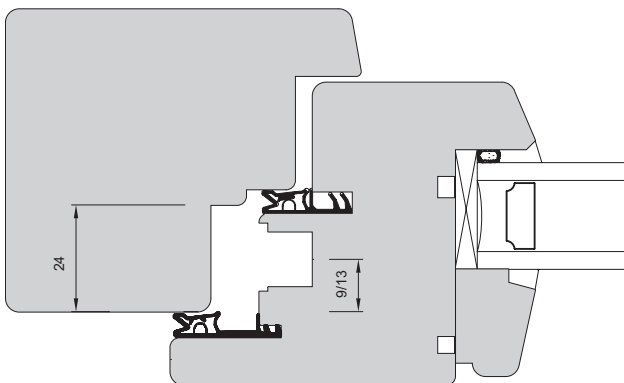

B-11-9: Rebate shape
Standard rebate 24 mm 9/13 mm NML

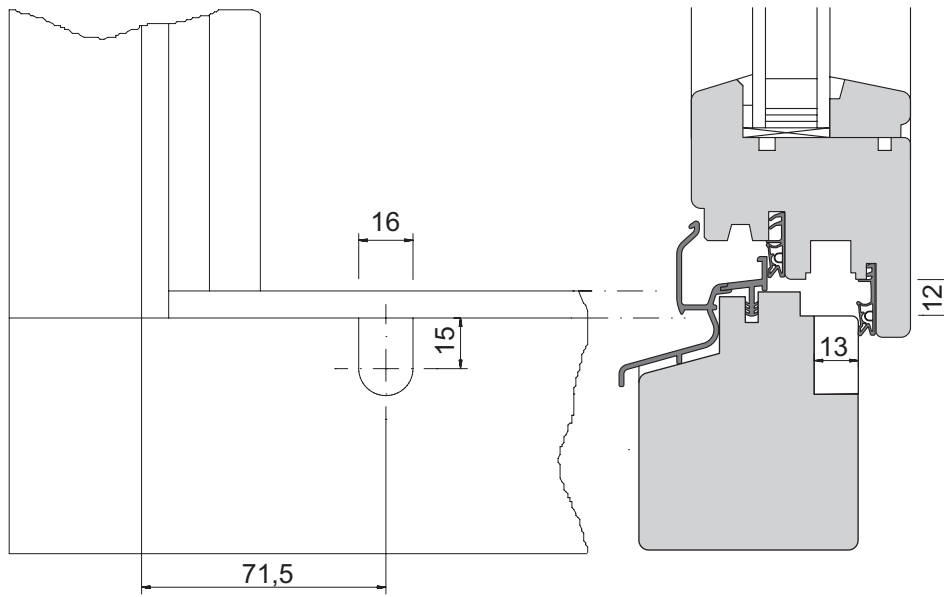

B-11-10: Installation drawing Rotation Stop DS.SBK.H...

Aug. Winkhaus GmbH & Co. KG

August-Winkhaus-Straße 31

D-48291 Telgte

T +49 2504 921-0

F +49 2504 921-340

fenstertechnik@winkhaus.de

winkhaus.com